

(Negativna)

povratna

sprega

Negativna i pozitivna povratna sprega

NPS-ravnoteža, stabilnost

PPS-divergencija, nestabilnost

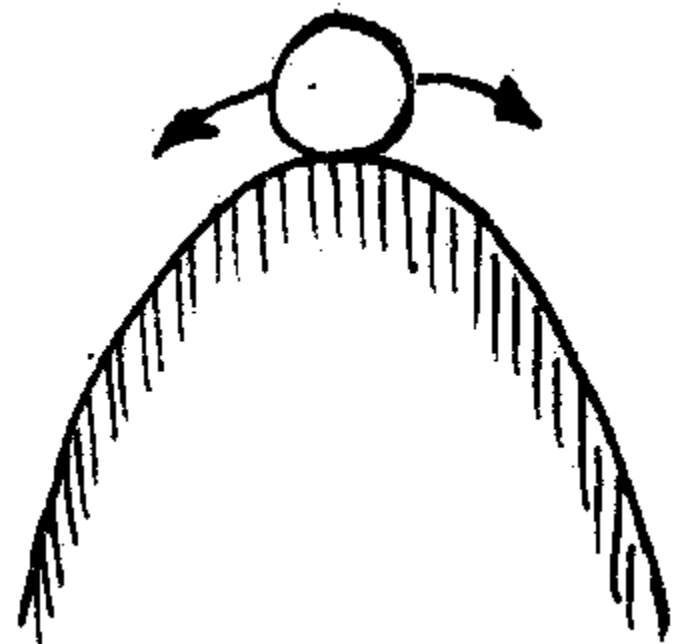
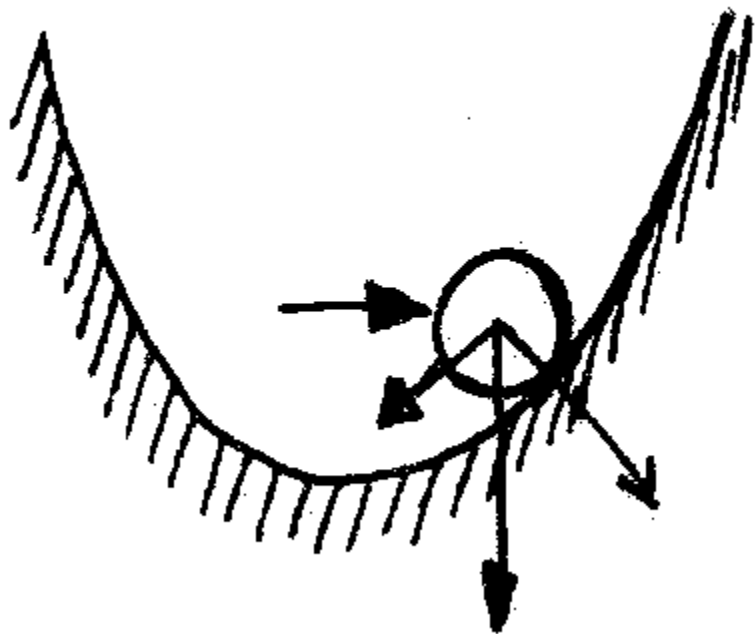

NPS i PPS

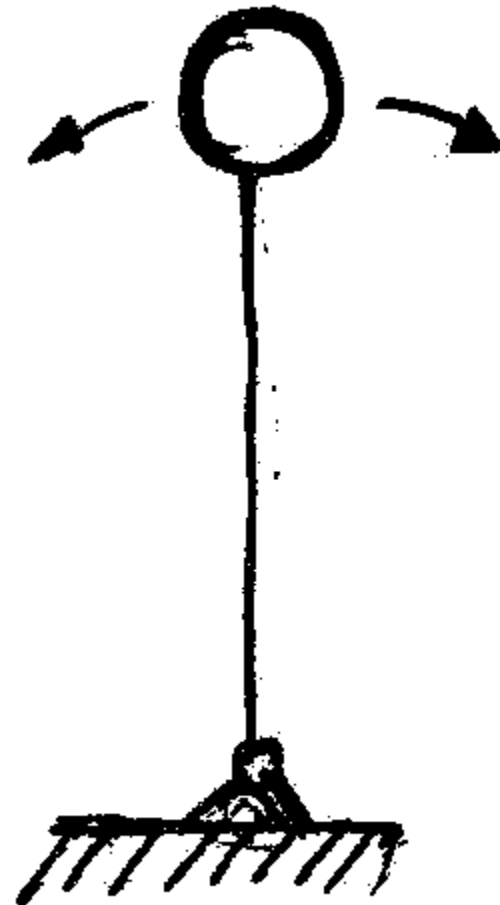
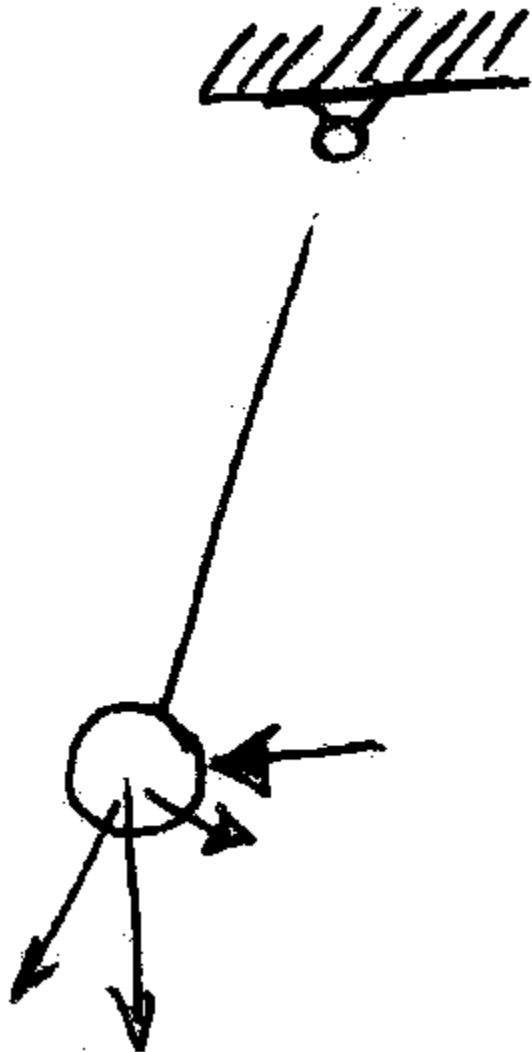

Kod NPS odziv konture je nasuprot početne pobude

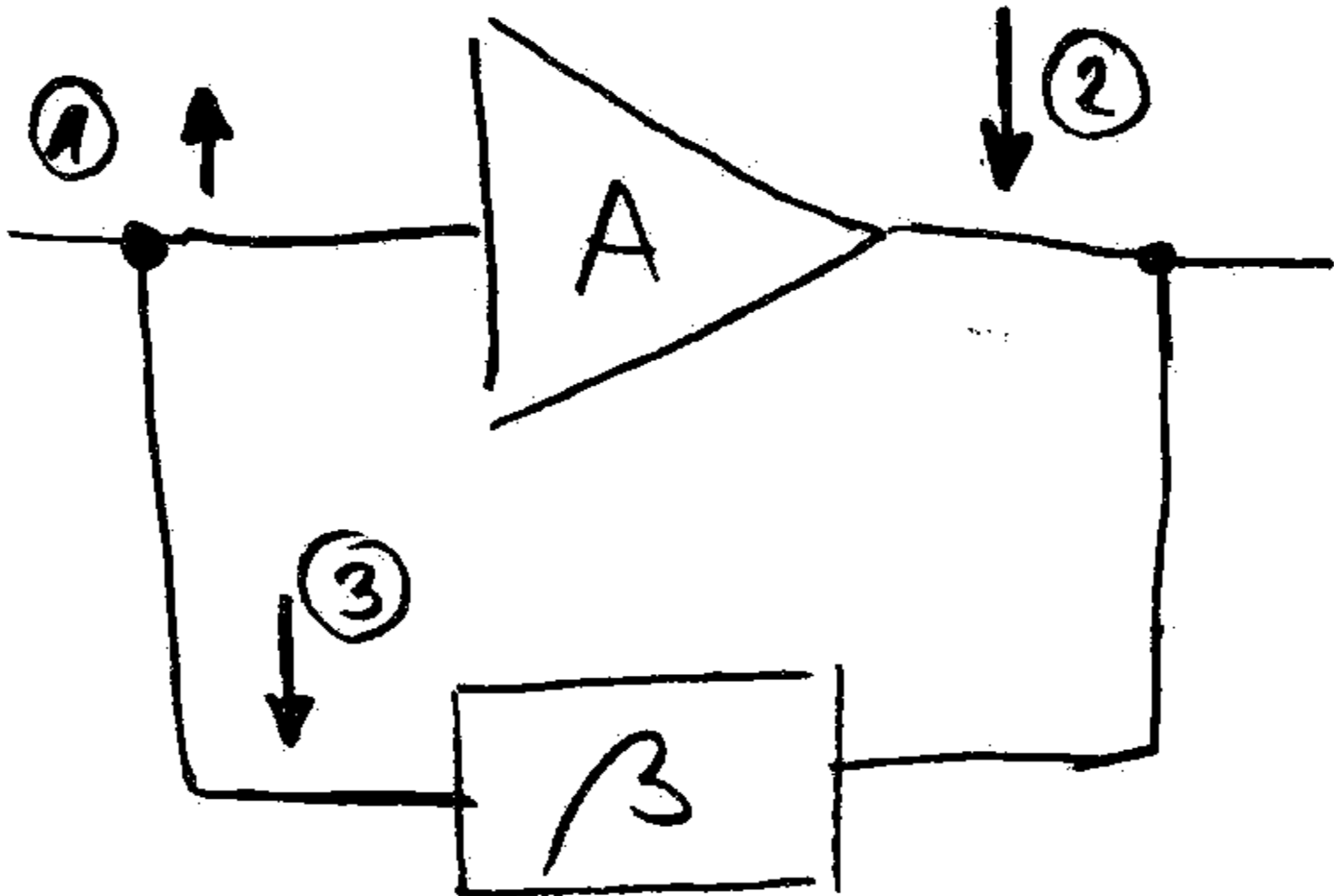

Kolo može imati i NPS i PPS

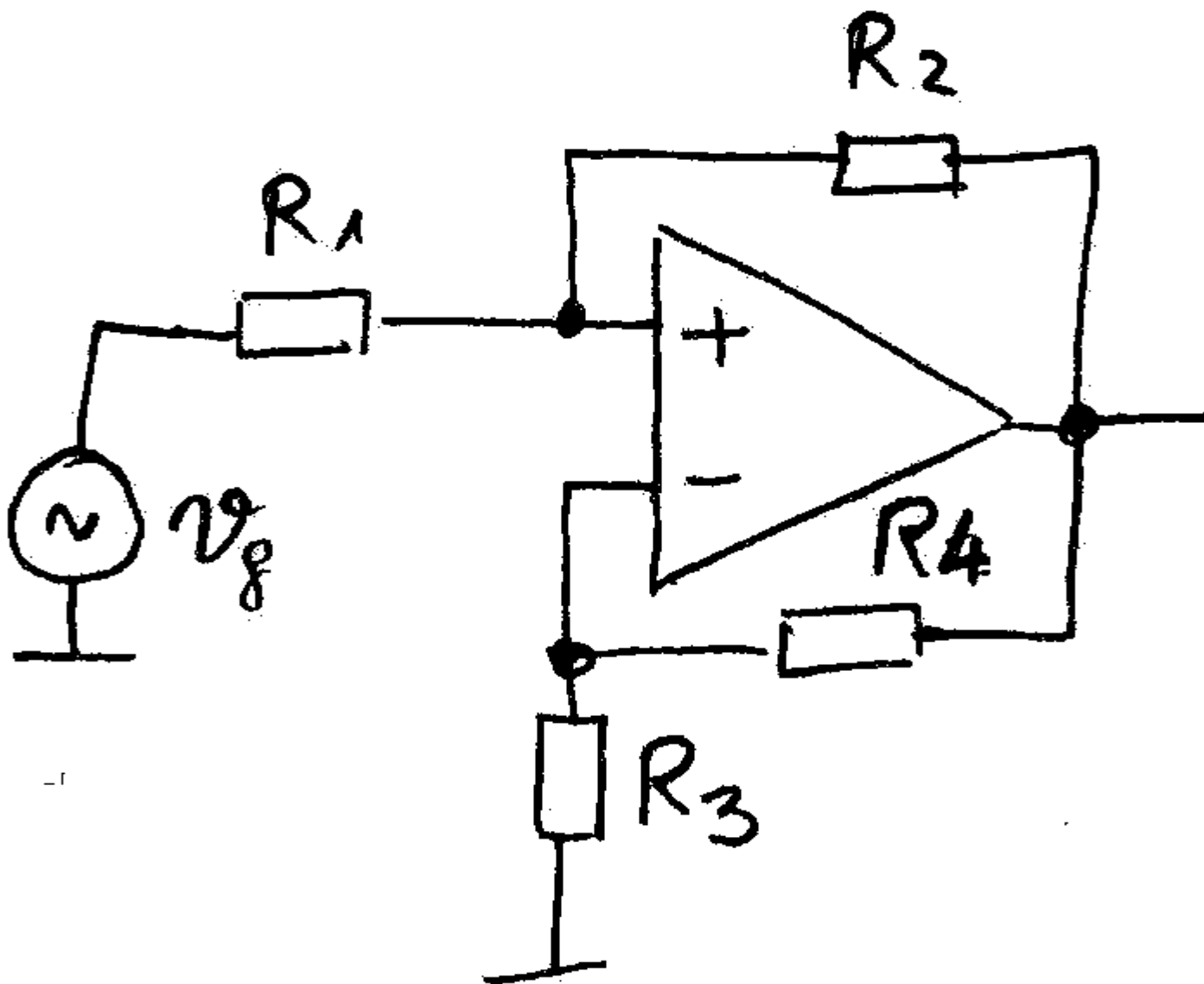

NPS na niskim, a PPS na visokim frek.

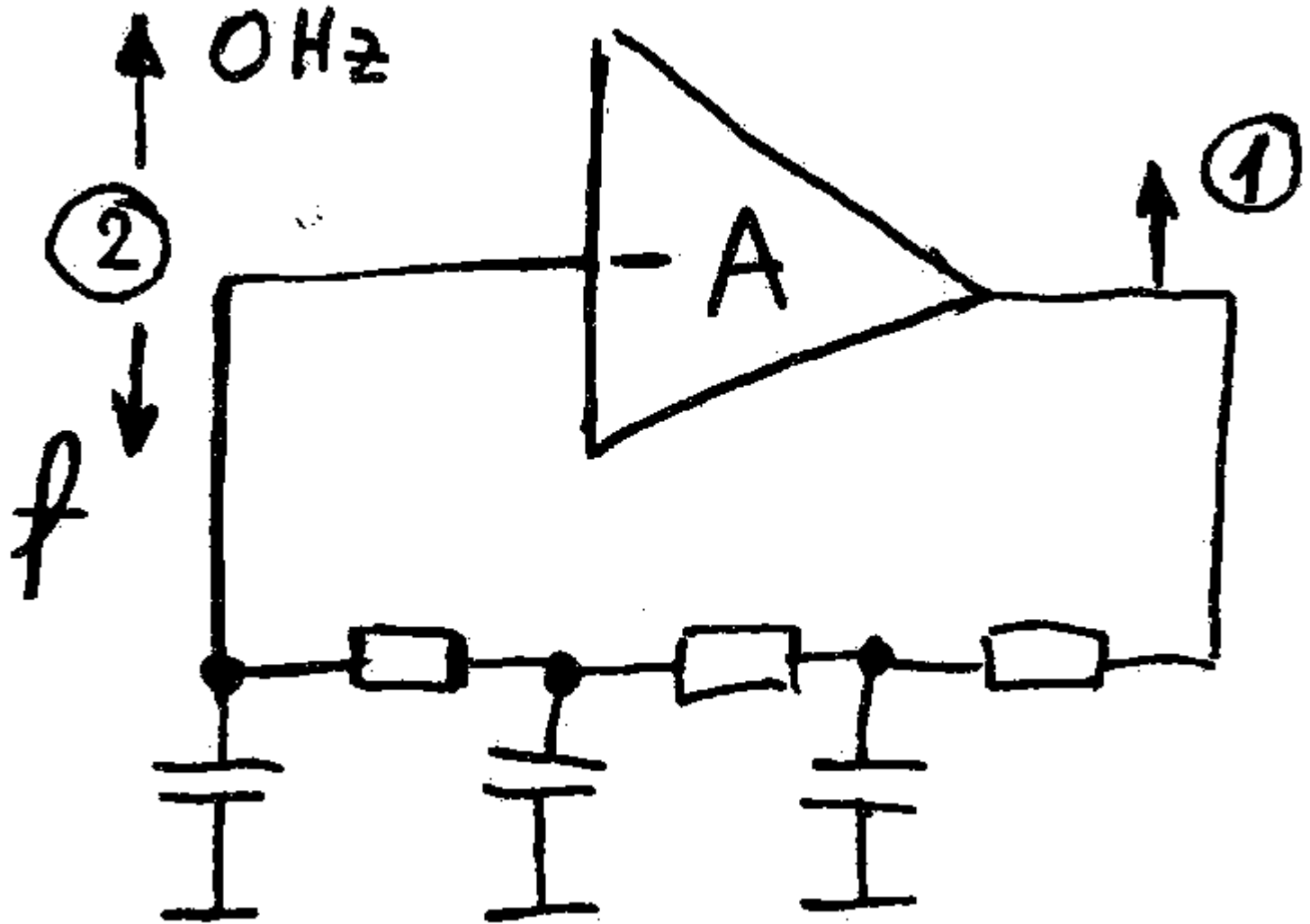

NPS ... A je negativno

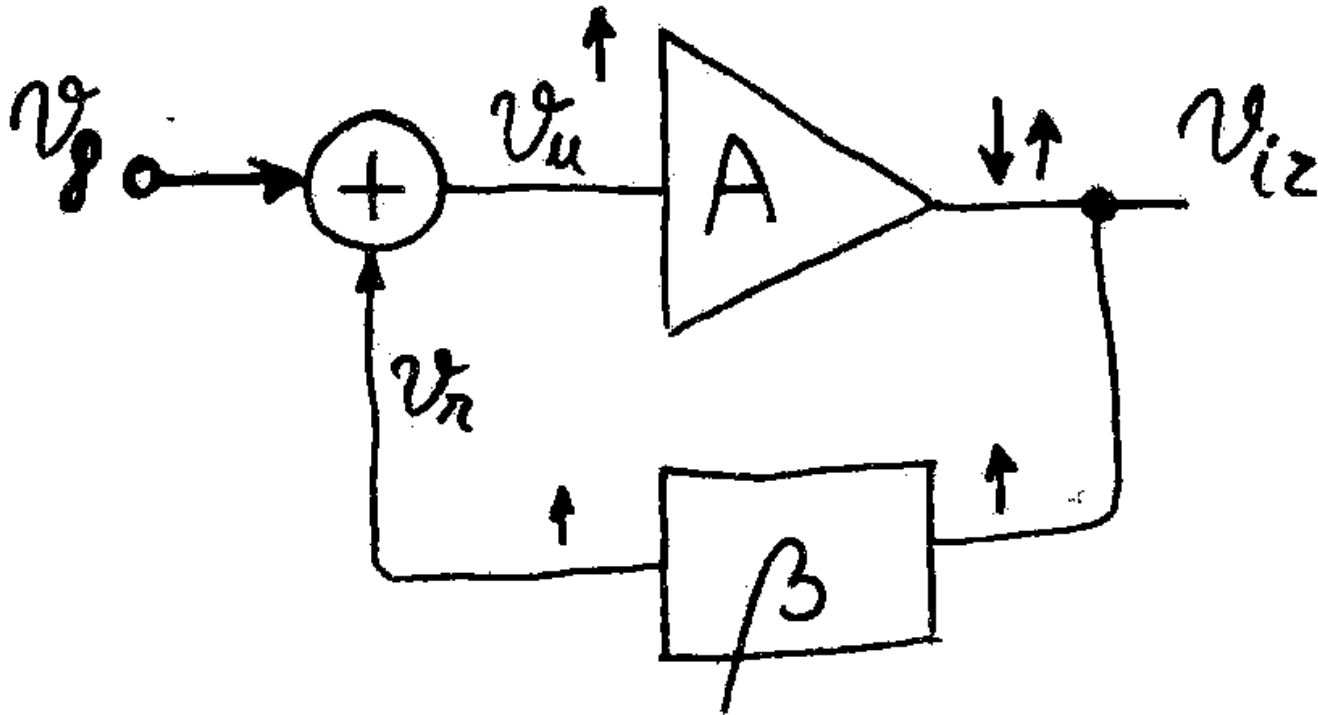

$$\left. \begin{aligned} v_u &= v_g + v_n \\ v_n &= \beta \cdot v_{iz} \\ v_{iz} &= A \cdot v_u \end{aligned} \right\} \Rightarrow \frac{v_{iz}}{v_g} = \frac{A}{1 - A\beta} = A_n$$

Osnovni pojmovi

A_{β} = кружно појавље

$1 - A_{\beta}$ = функција реакције

A_n = појавље са реакцијом

A = појавље у отвореној контури

\mathcal{U}_n = нетон (сигнал) реакције

\mathcal{U}_u = улазни нетон

\mathcal{U}_p = подурни нетон

Uticaj NPS na konstantnost pojačanja

$$A = A(T, t, V_{cc}, R_p, N, \dots)$$

$\frac{dA}{A}$, $\frac{\Delta A}{A}$ relativna promjena A

$$\frac{dA_n}{A_n} = \frac{d\left(\frac{A}{1-A\beta}\right)}{\frac{A}{1-A\beta}} = \frac{\frac{dA}{A}}{1-A\beta}$$

Odrediti + i - ulaze na OP

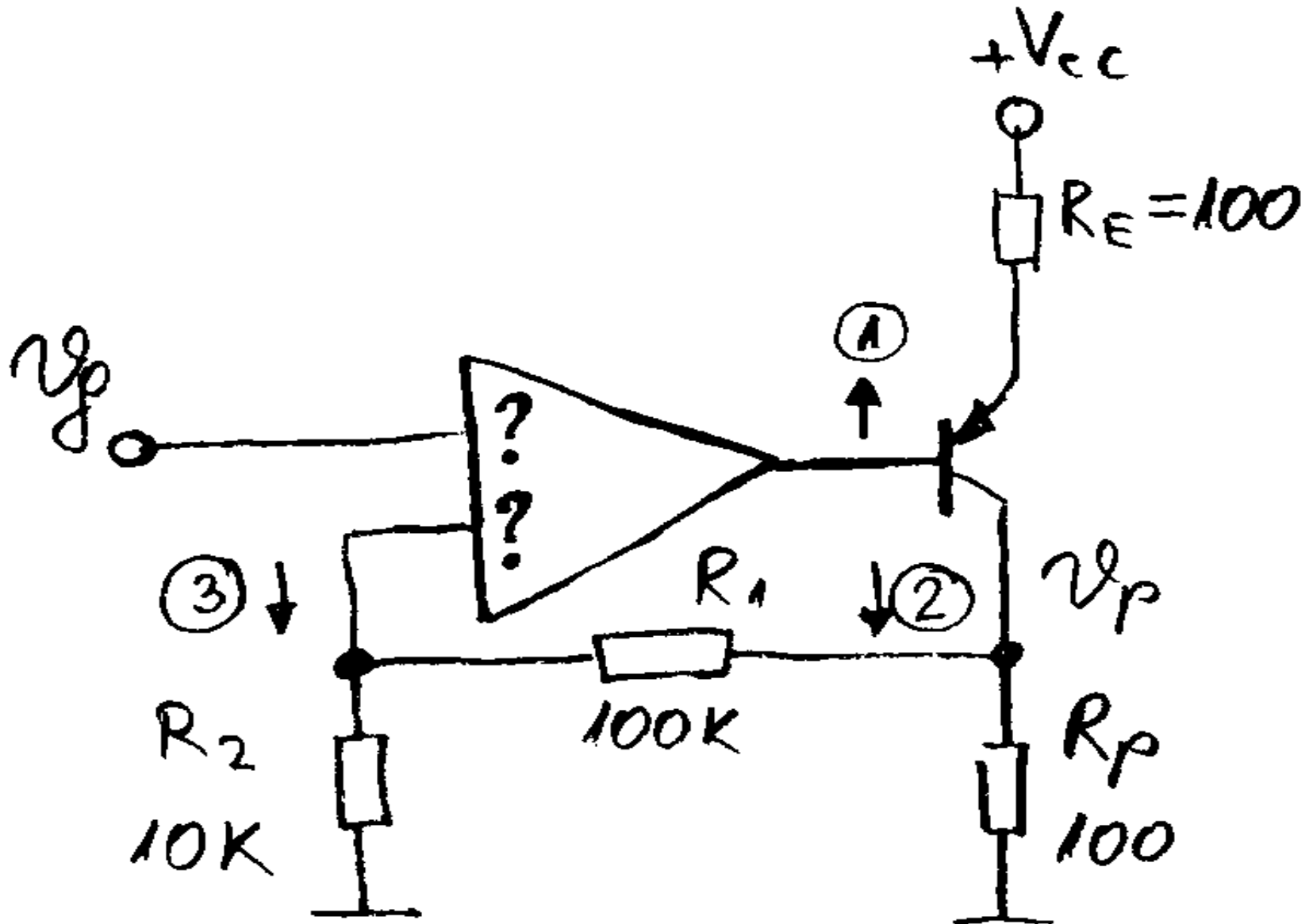

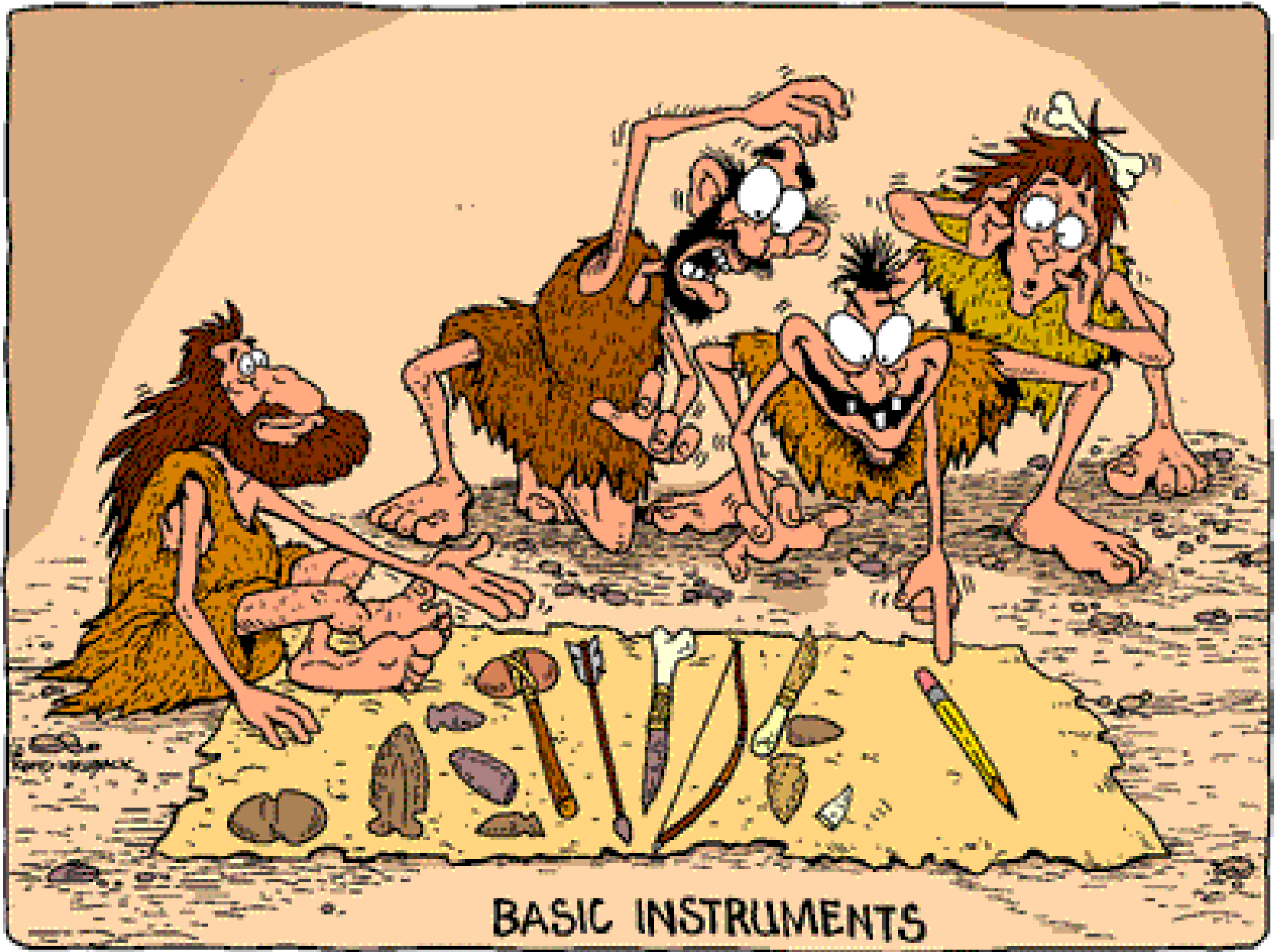

BASIC INSTRUMENTS

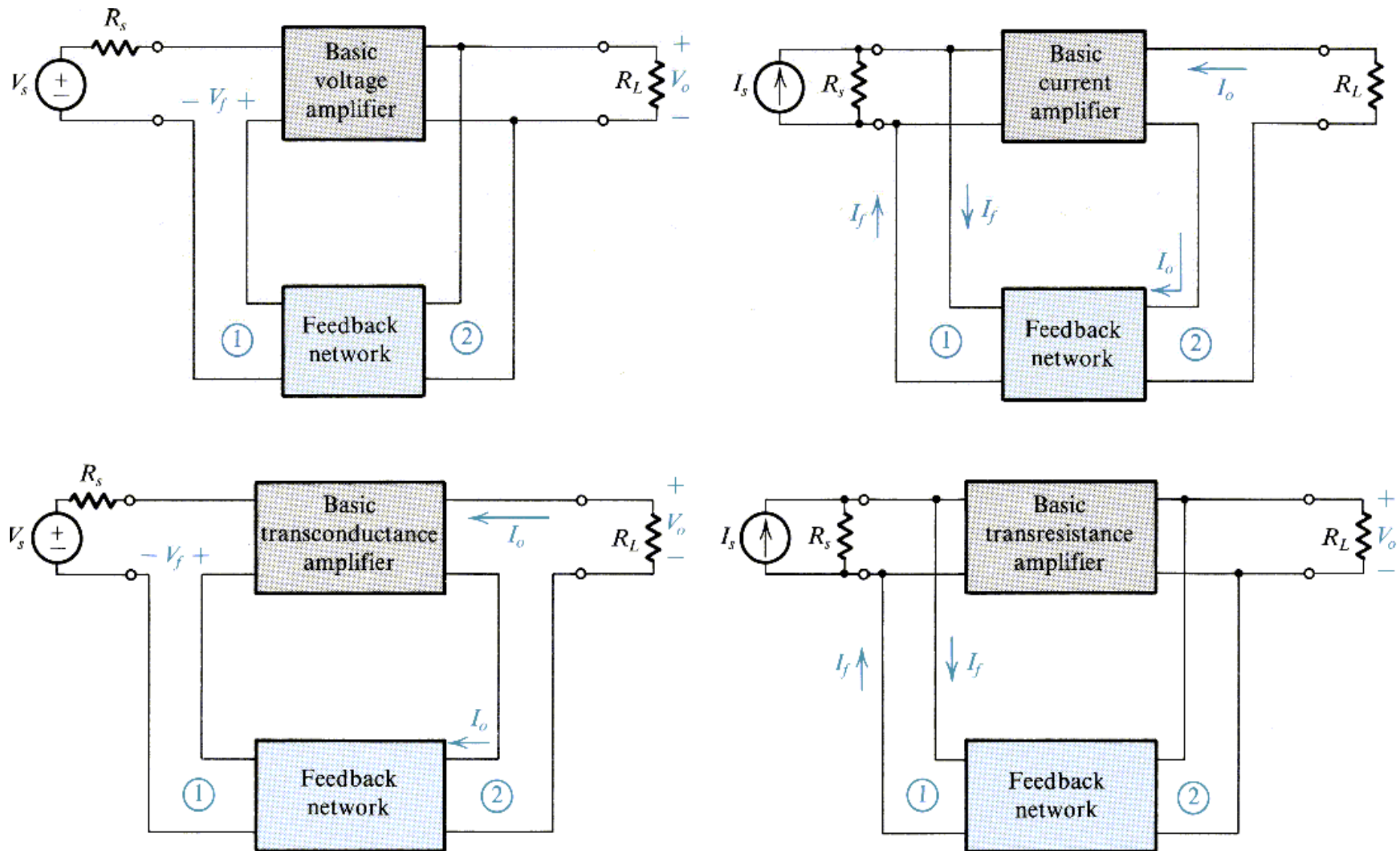

Fig. 8.4 The four basic feedback topologies: (a) voltage-sampling series-mixing (series-shunt) topology; (b) current-sampling shunt-mixing (shunt-series) topology; (c) current-sampling series-mixing (series-series) topology; (d) voltage-sampling shunt-mixing (shunt-shunt) topology.

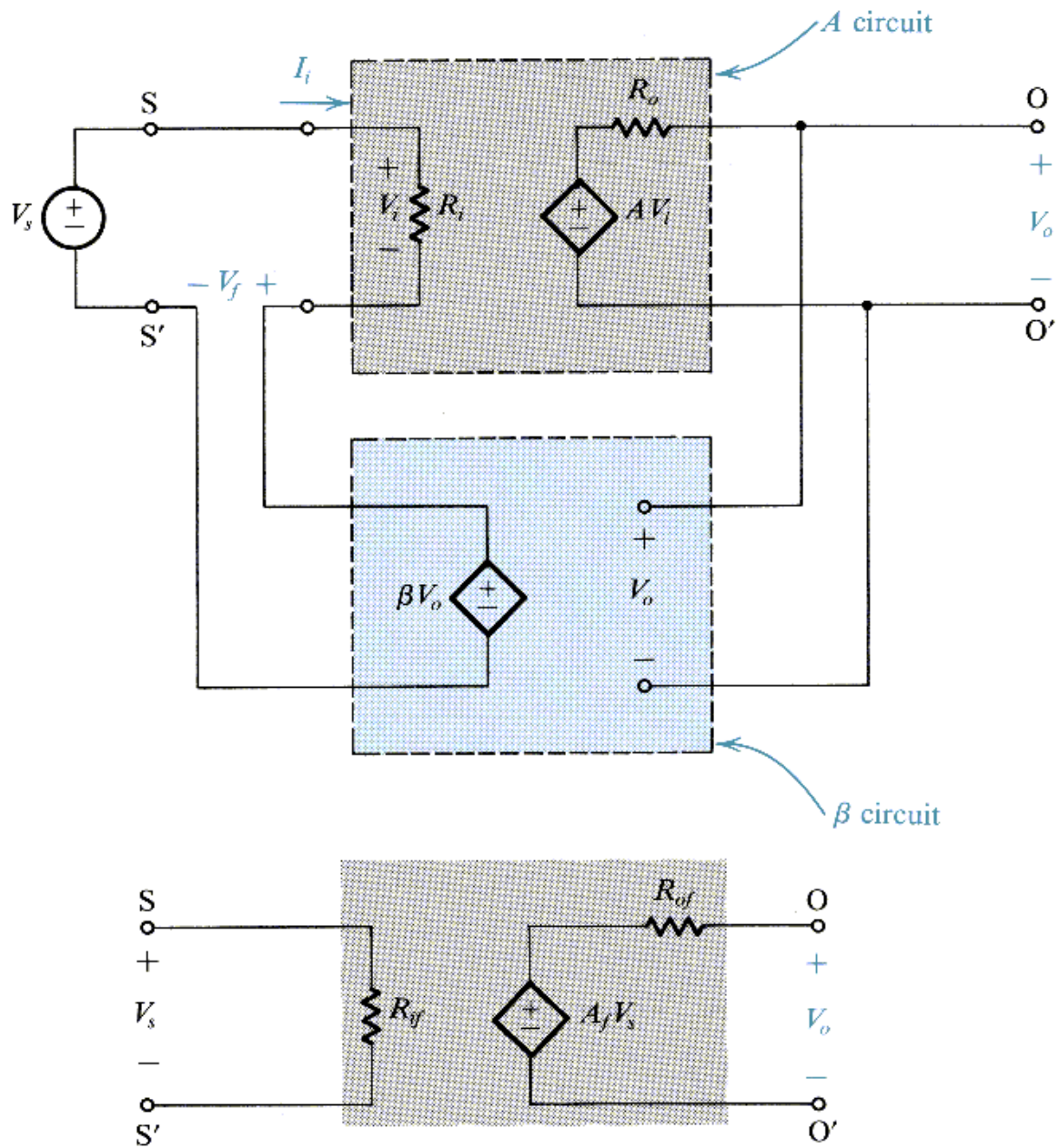

Fig. 8.8 The series-shunt feedback amplifier: (a) ideal structure; (b) equivalent circuit.

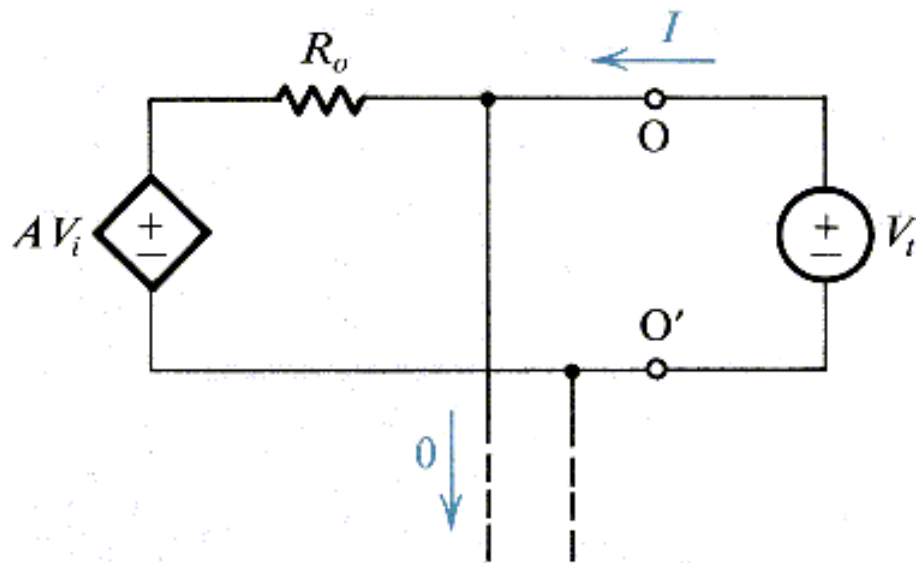

Fig. 8.9 Measuring the output resistance of the feedback amplifier of Fig. 8.8 (a): $R_{of} = V_t/I$.

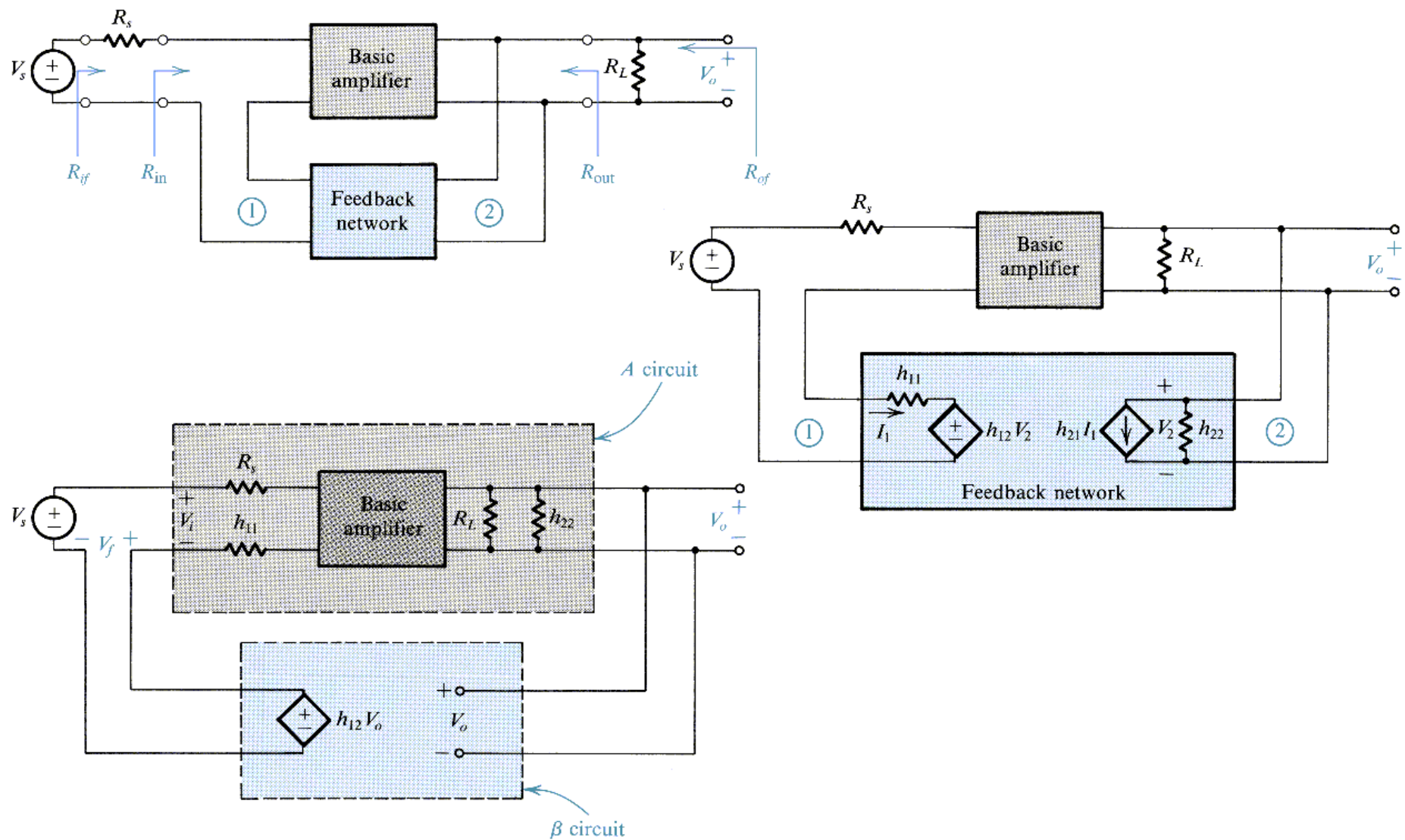

Fig. 8.10 Derivation of the A circuit and β circuit for the series-shunt feedback amplifier. (a) Block diagram of a practical series-shunt feedback amplifier. (b) The circuit in (a) with the feedback network represented by its h parameters. (c) The circuit in (b) after neglecting h_{21} .

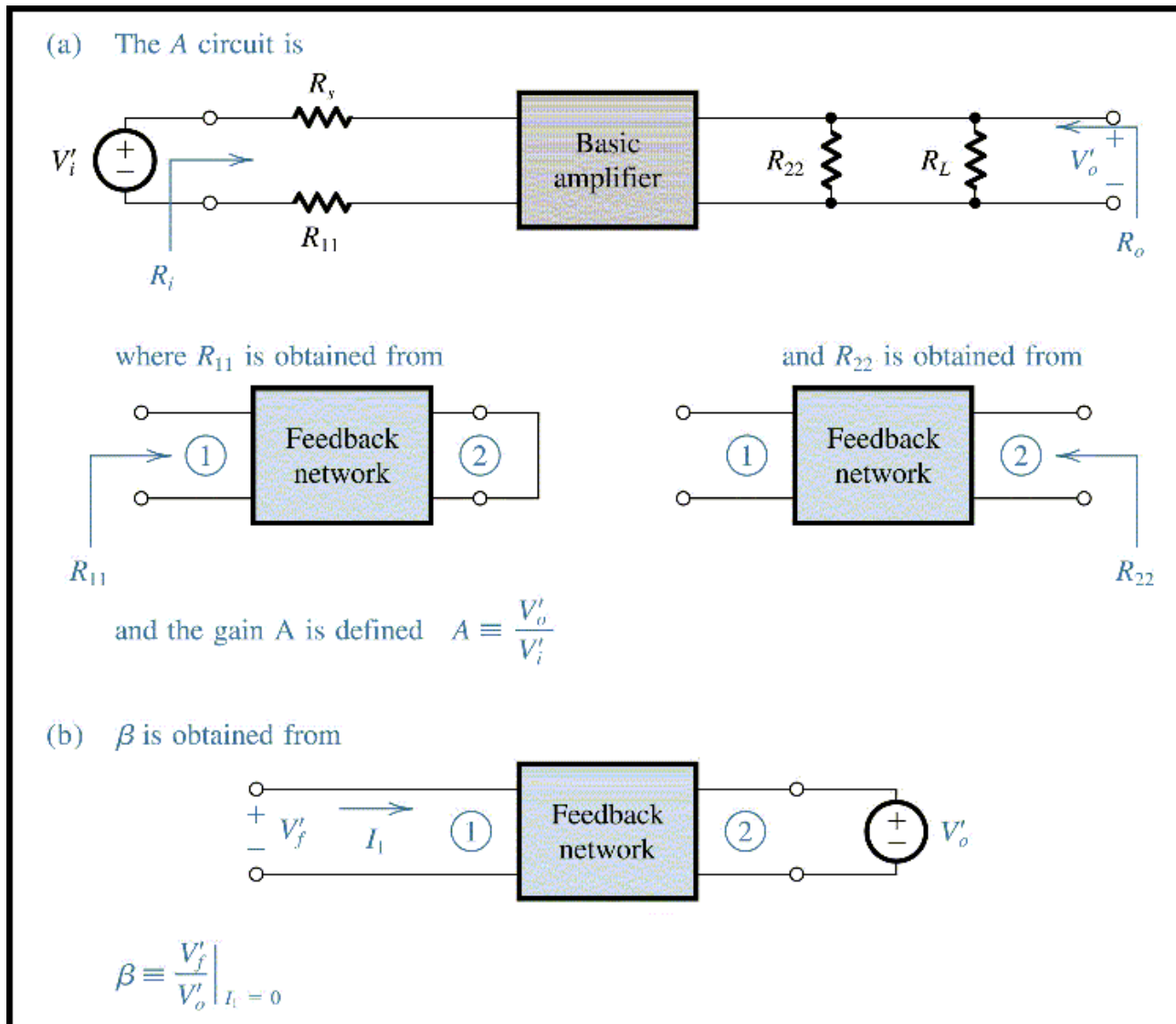

Fig. 8.11 Summary of the rules for finding the A circuit and β for the voltage-sampling series-mixing case of Fig. 8.10(a).

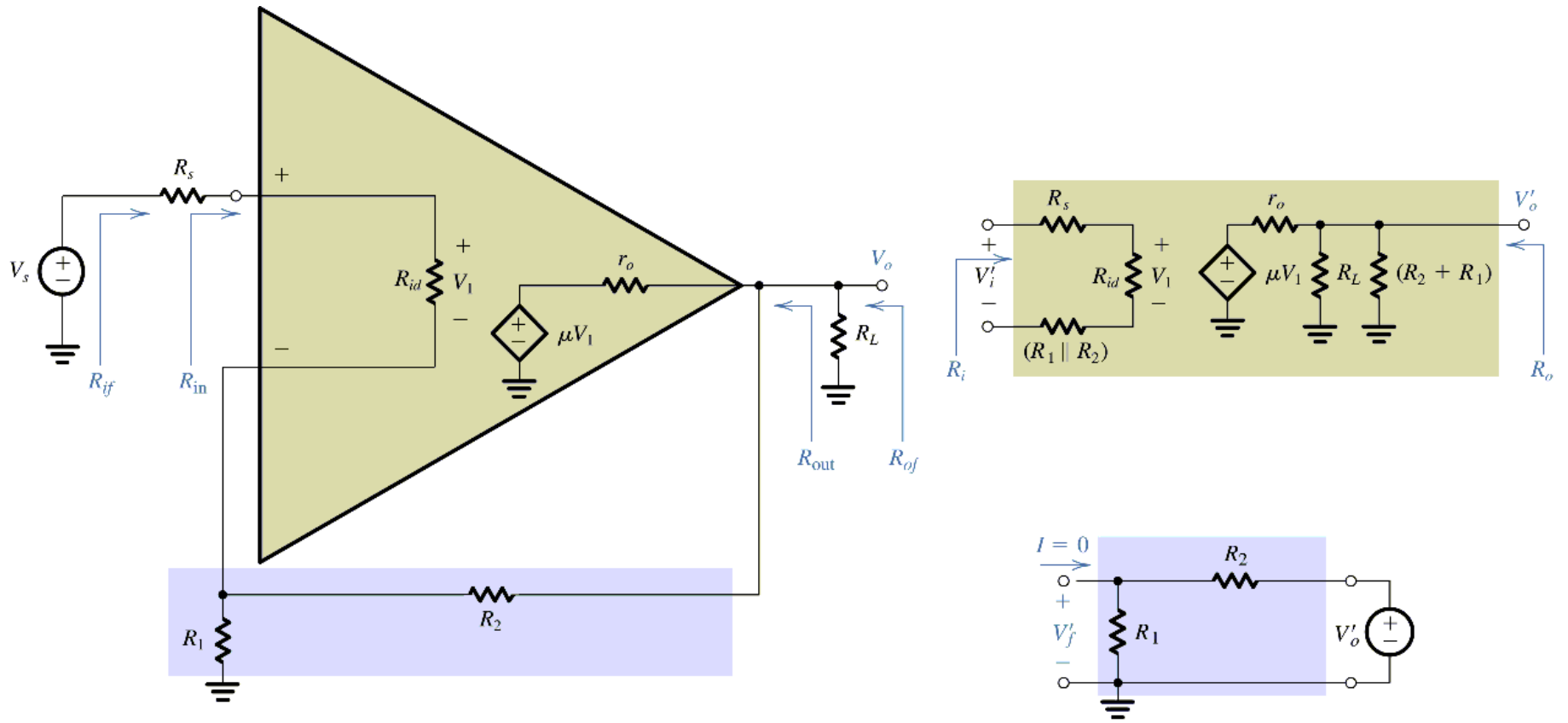

Fig. 8.12 Circuits for Example 8.1.

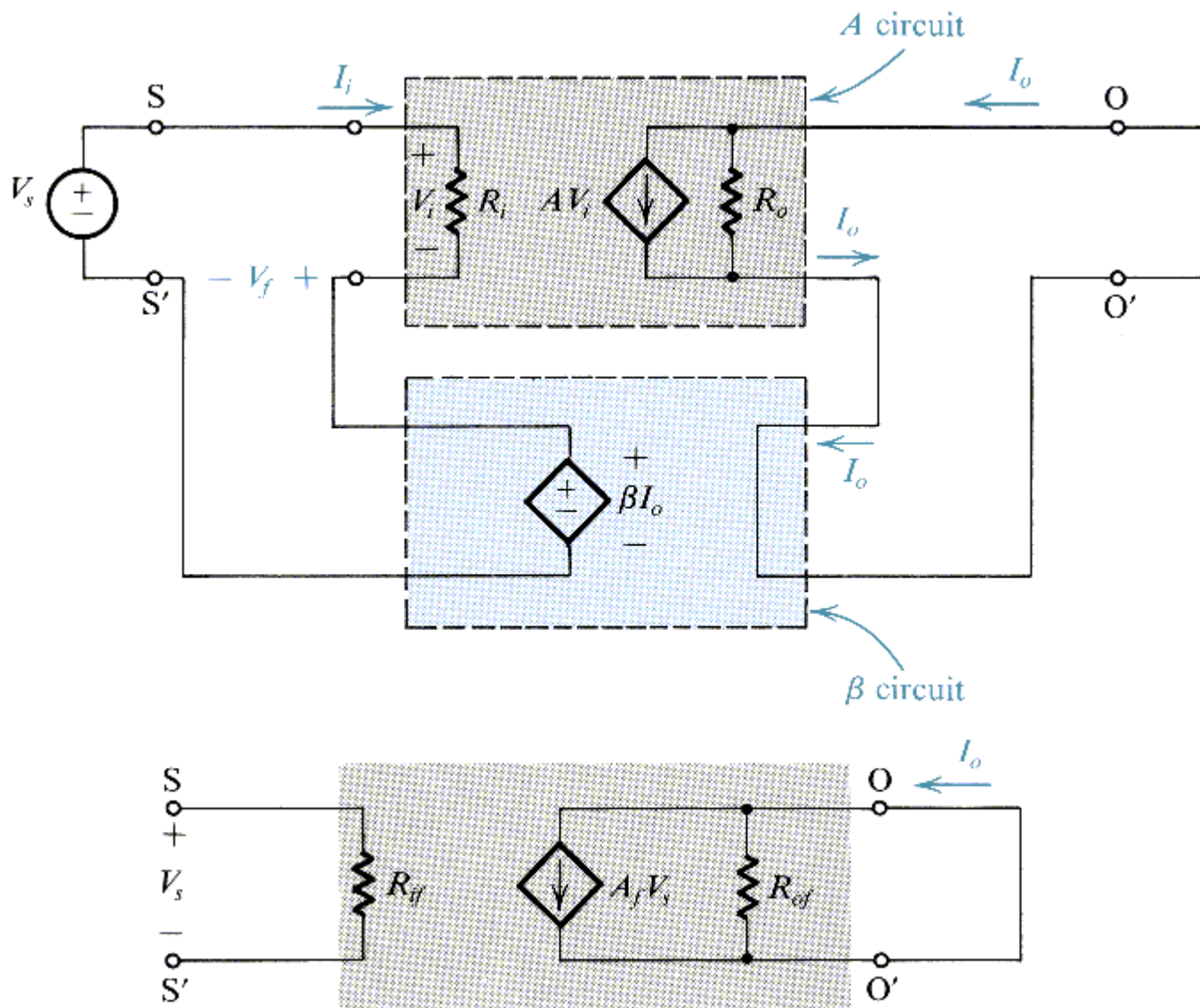

Fig. 8.13 The series-series feedback amplifier: (a) ideal structure; (b) equivalent circuit.

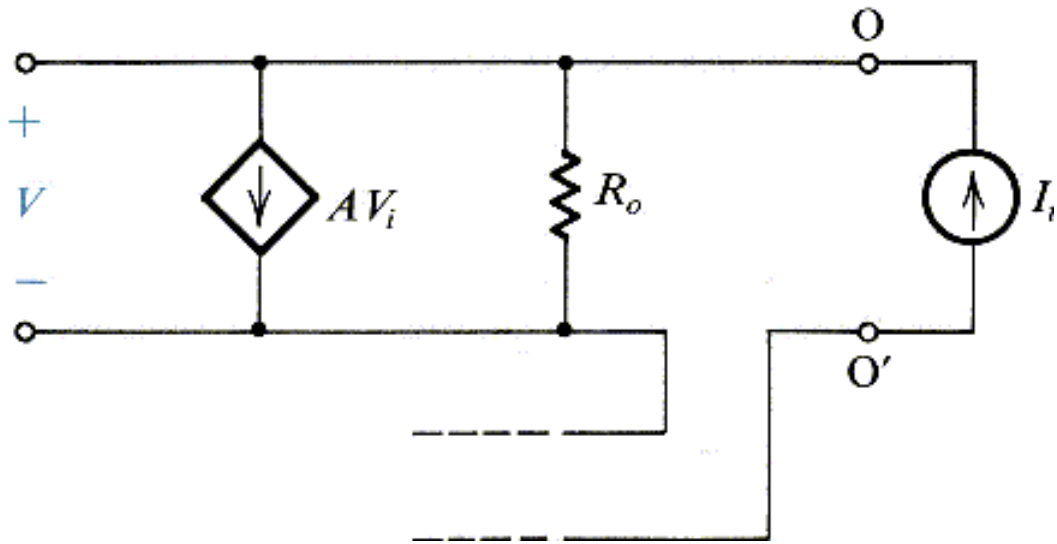

Fig. 8.14 Measuring the output resistance R_{of} of the series-series feedback amplifier.

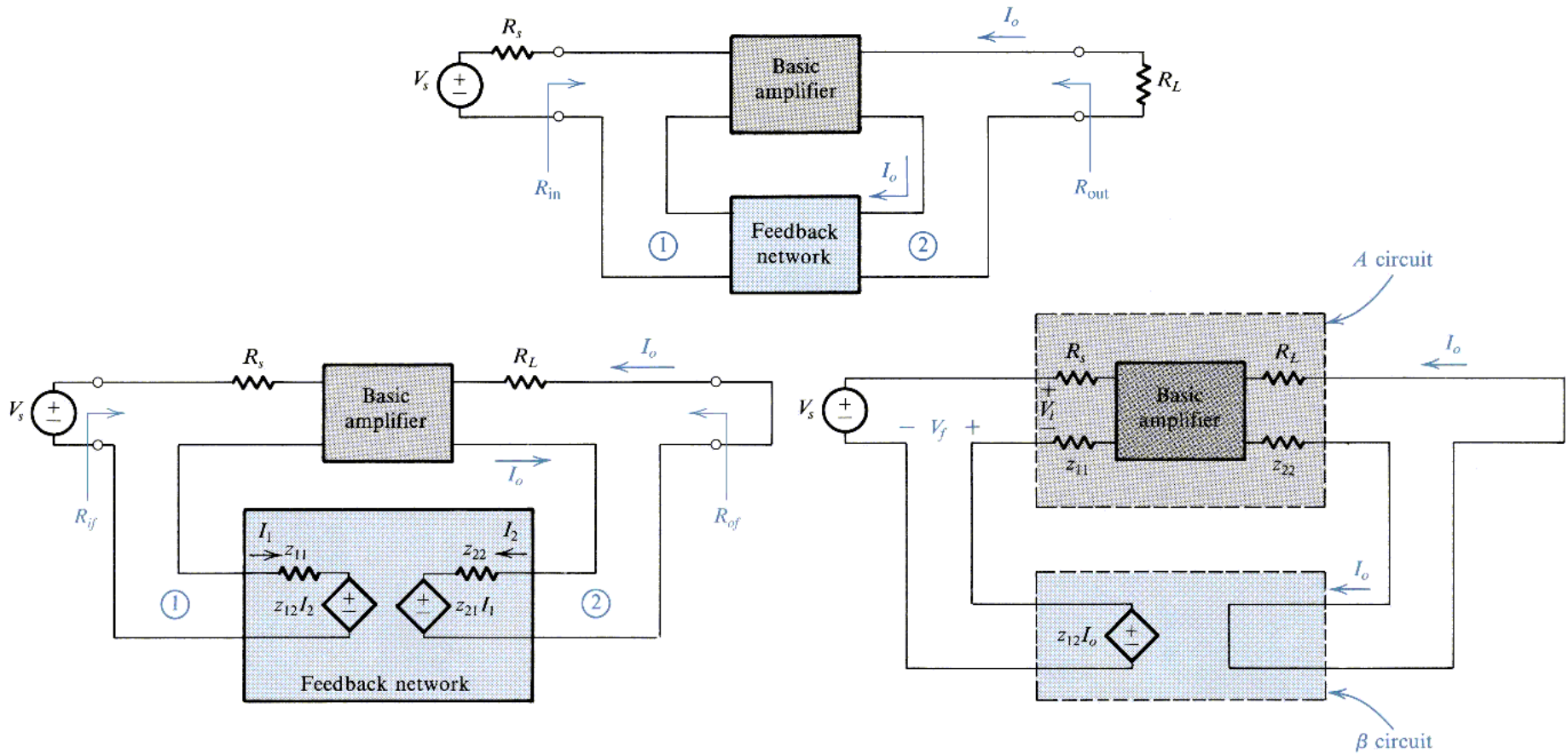

Fig. 8.15 Derivation of the A circuit and β circuit for the series-series feedback amplifiers. (a) A series-series feedback amplifier. (b) The circuit of (a) with the feedback network represented by its z parameters. (c) A redrawing of the circuit in (b) after neglecting z_{21} .

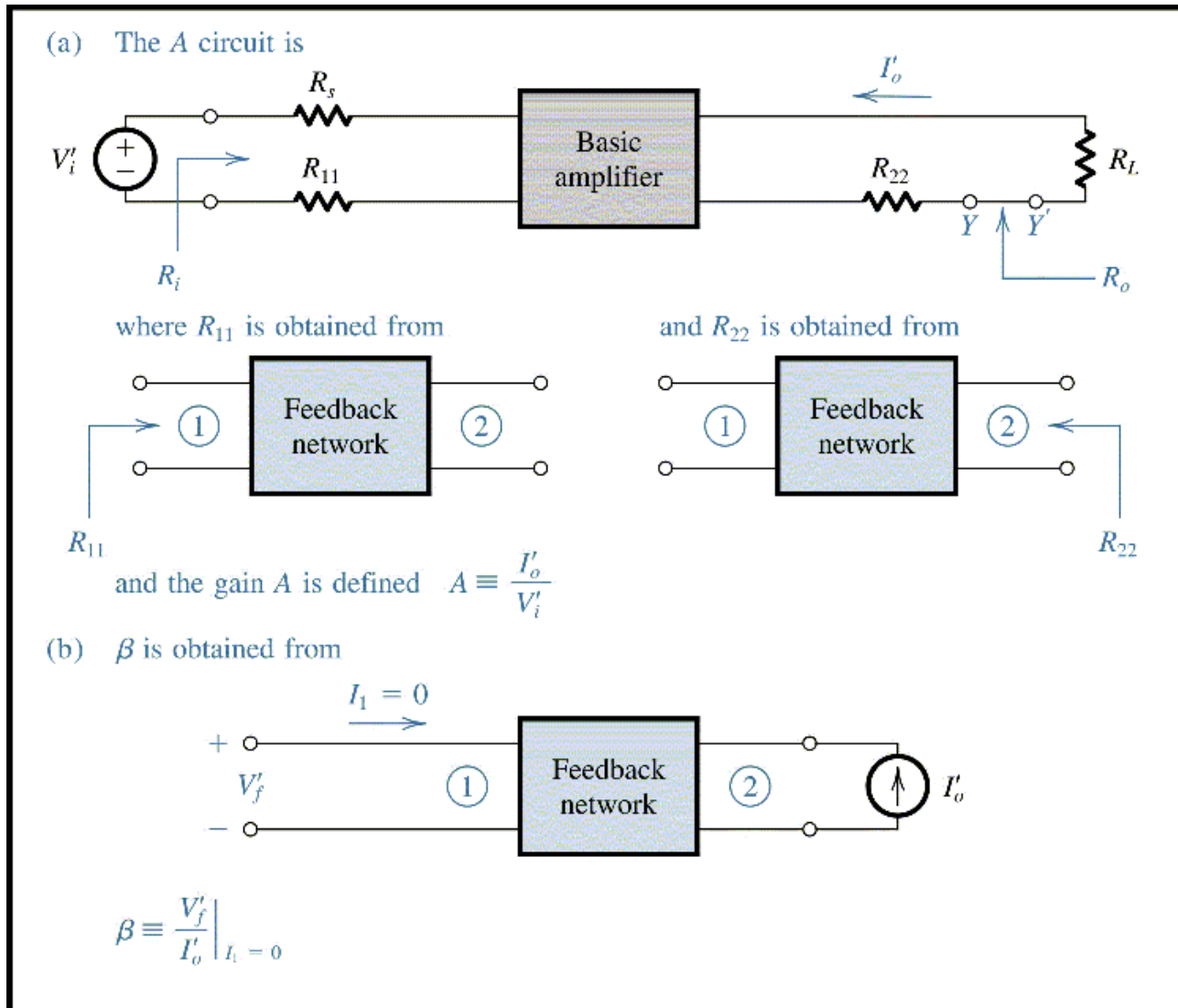

Fig. 8.16 Finding the A circuit and β for the current-sampling series-mixing (series-series) case.

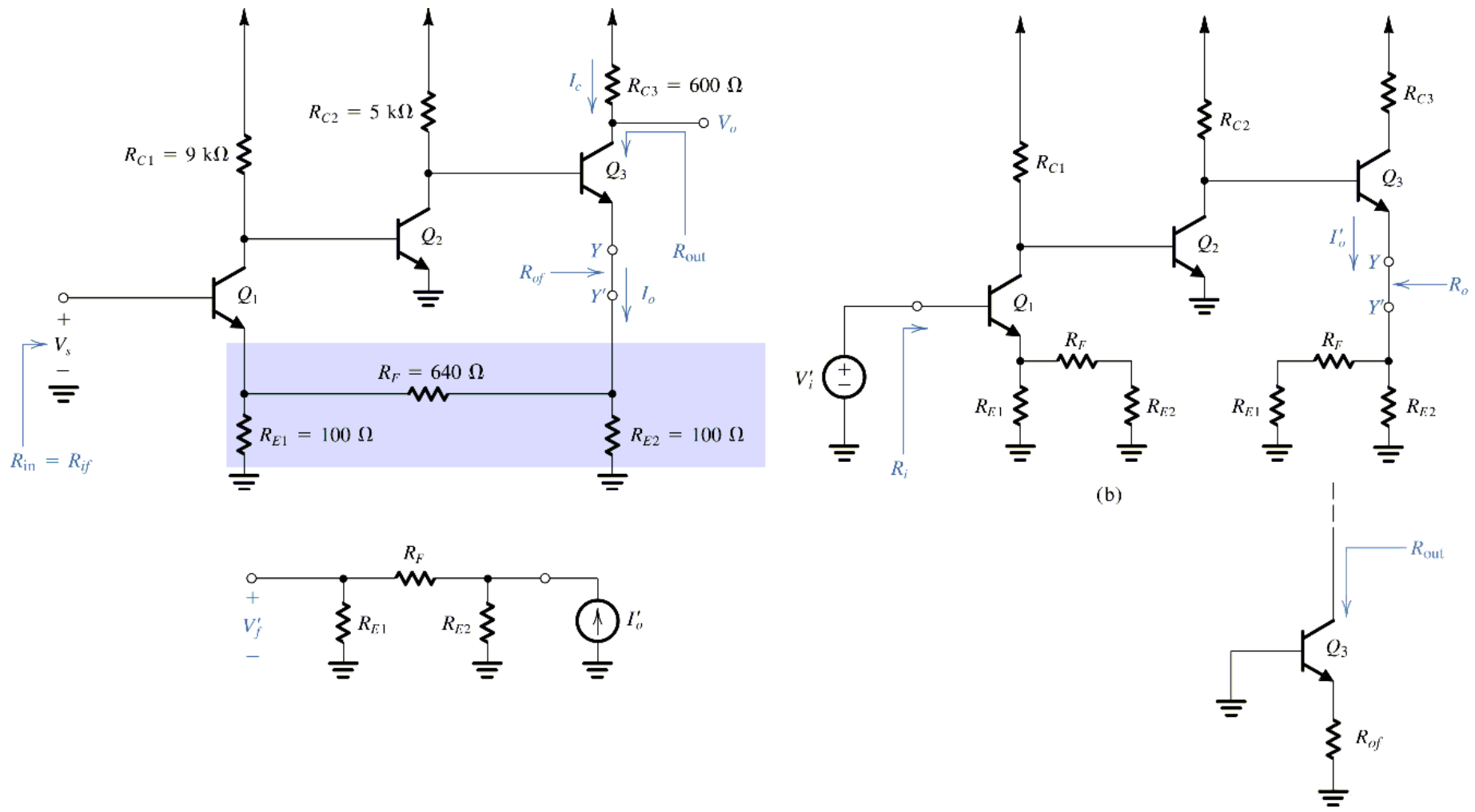

Fig. 8.17 Circuits for Example 8.2.

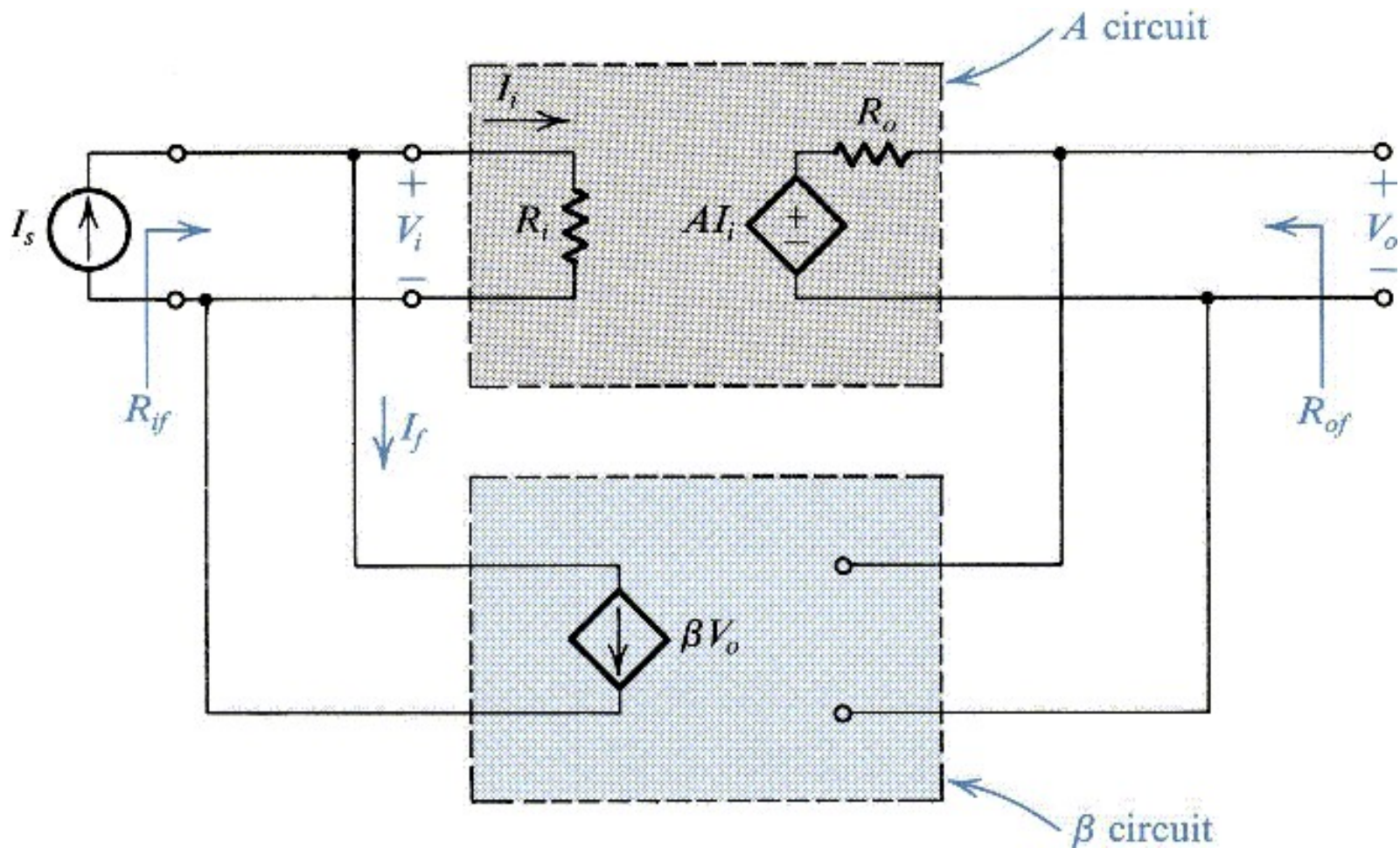

Fig. 8.18 Ideal structure for the shunt-shunt feedback amplifier.

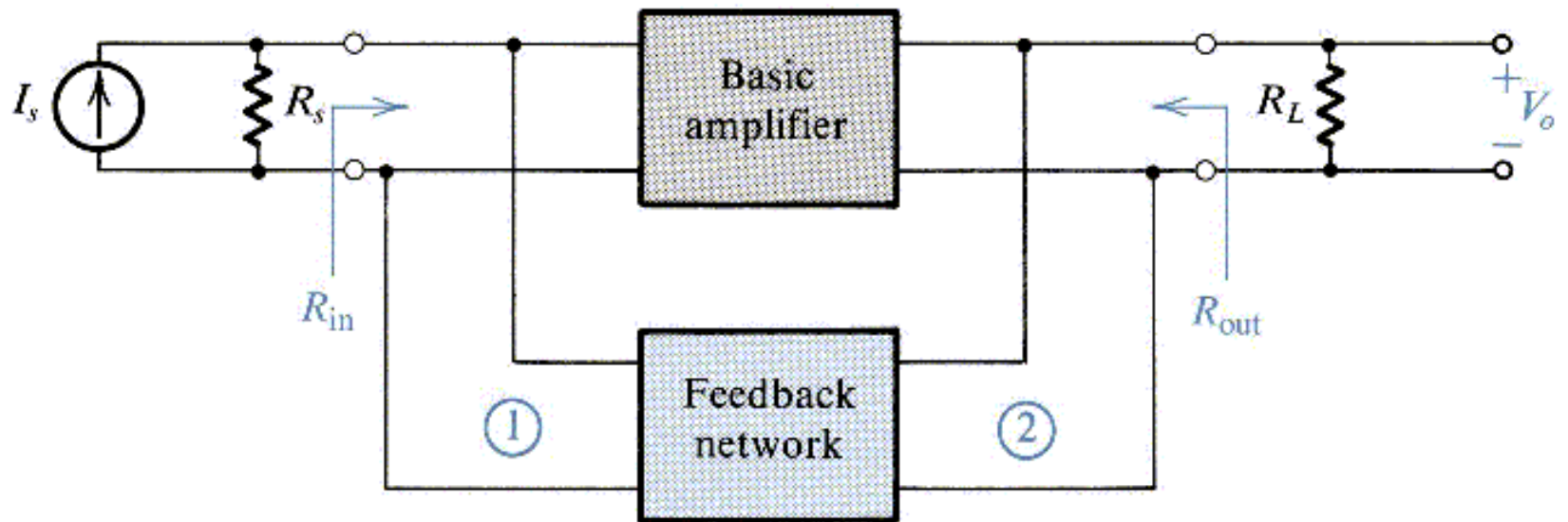

Fig. 8.19 Block diagram for a practical shunt-shunt feedback amplifier.

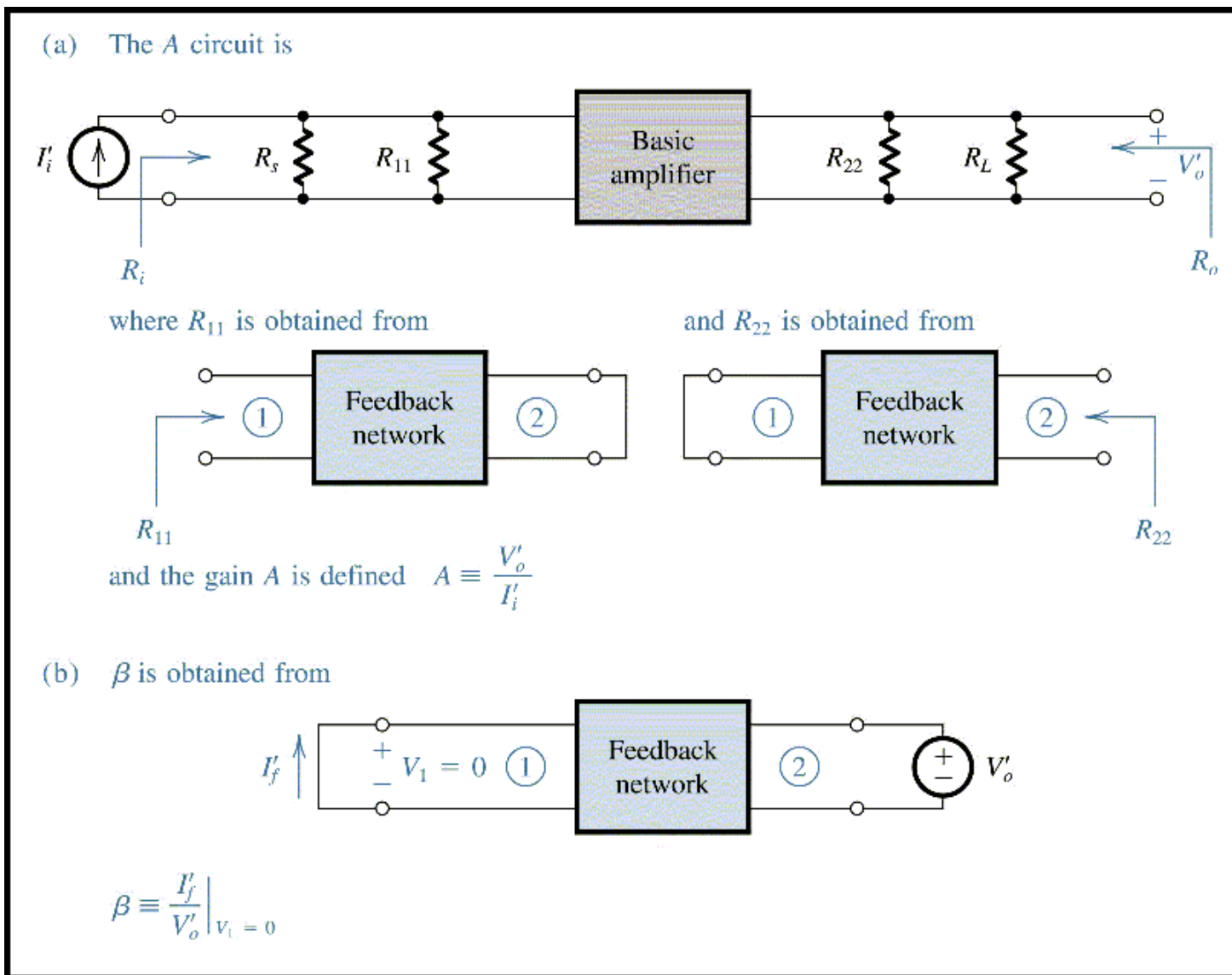

Fig. 8.20 Finding the A circuit and β for the voltage-sampling shunt-mixing (shunt-shunt) case.

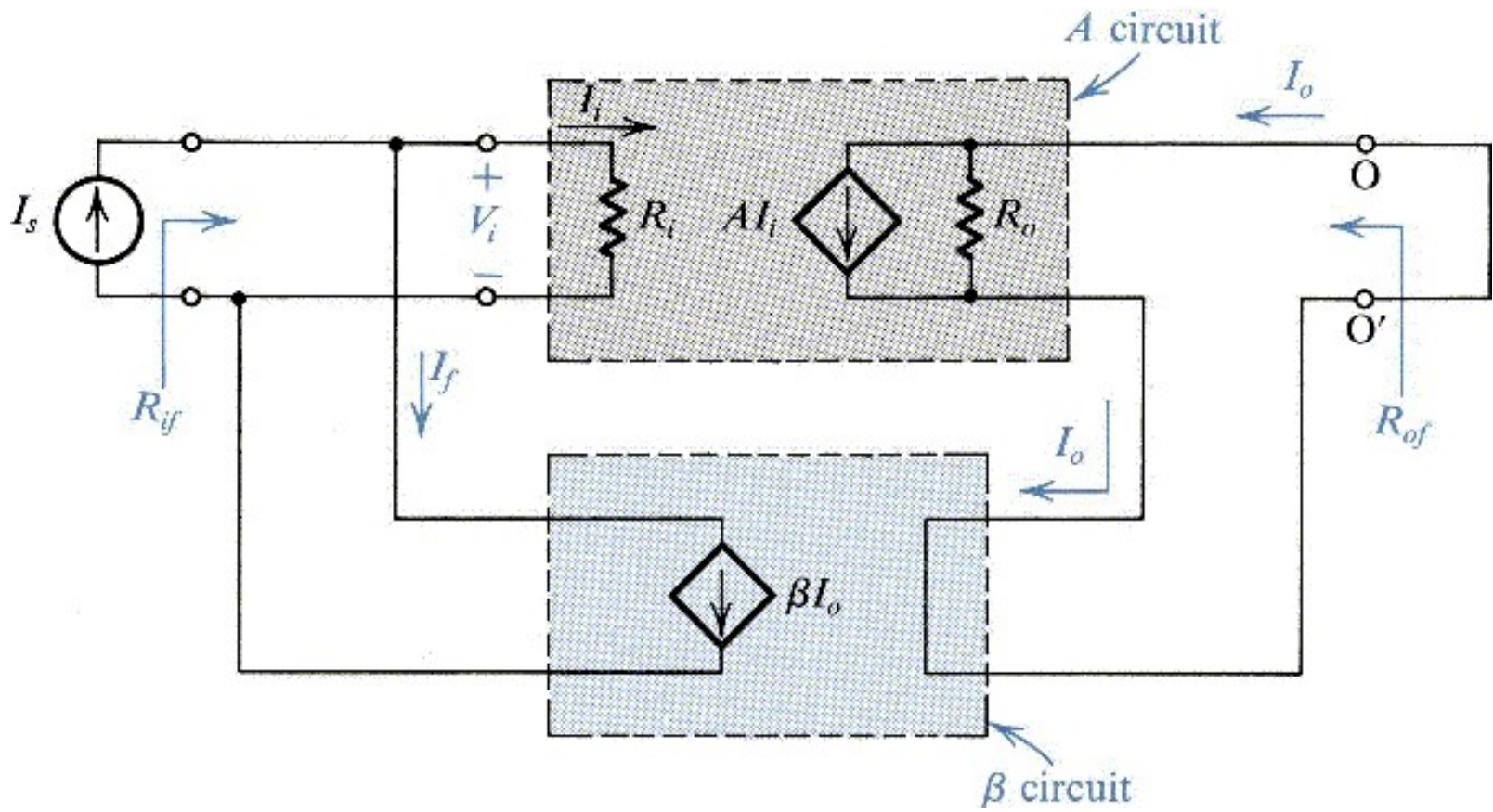

Fig. 8.22 Ideal structure for the shunt-series feedback amplifier.

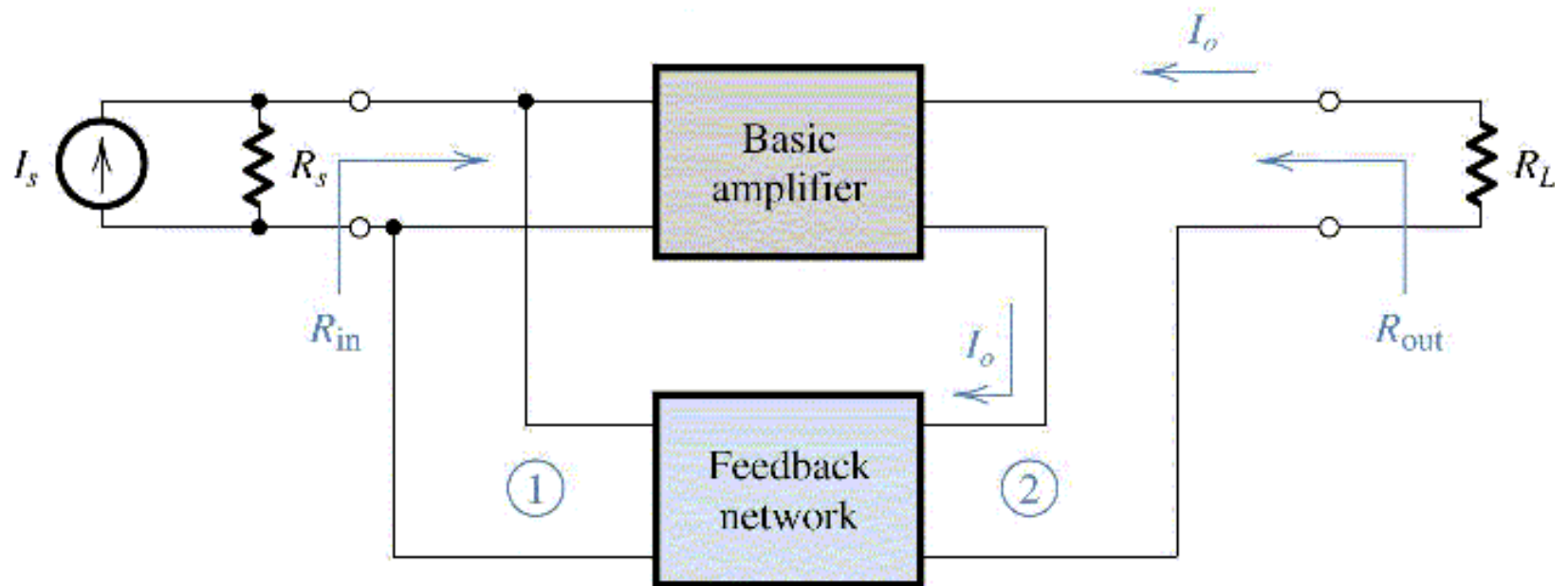

Fig. 8.23 Block diagram for practical shunt-series feedback amplifier

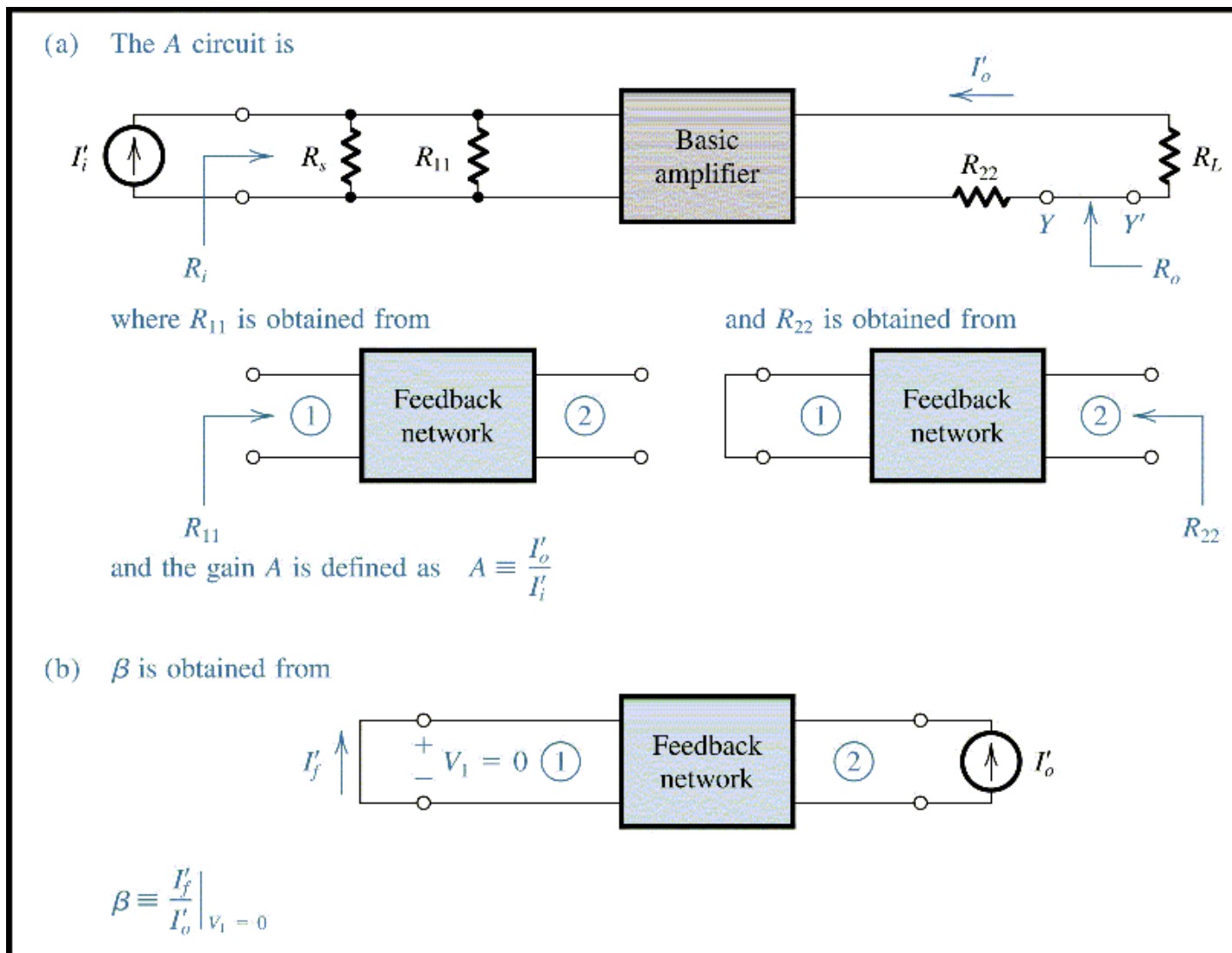

Fig. 8.24 Finding the A circuit and β for the current-sampling shunt-mixing (shunt-series) case.

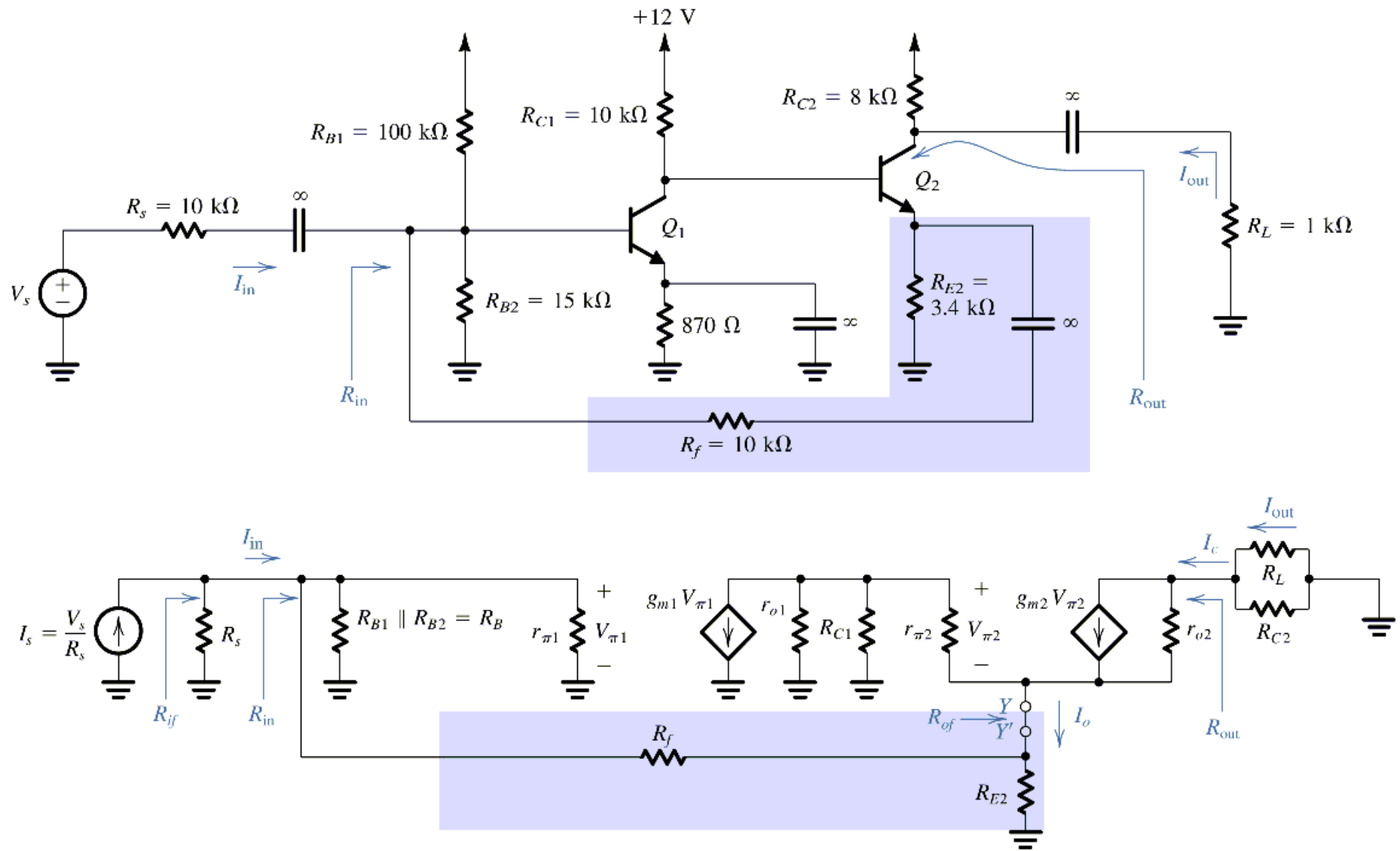

Fig. 8.25-1 Circuits for Example 8.4.

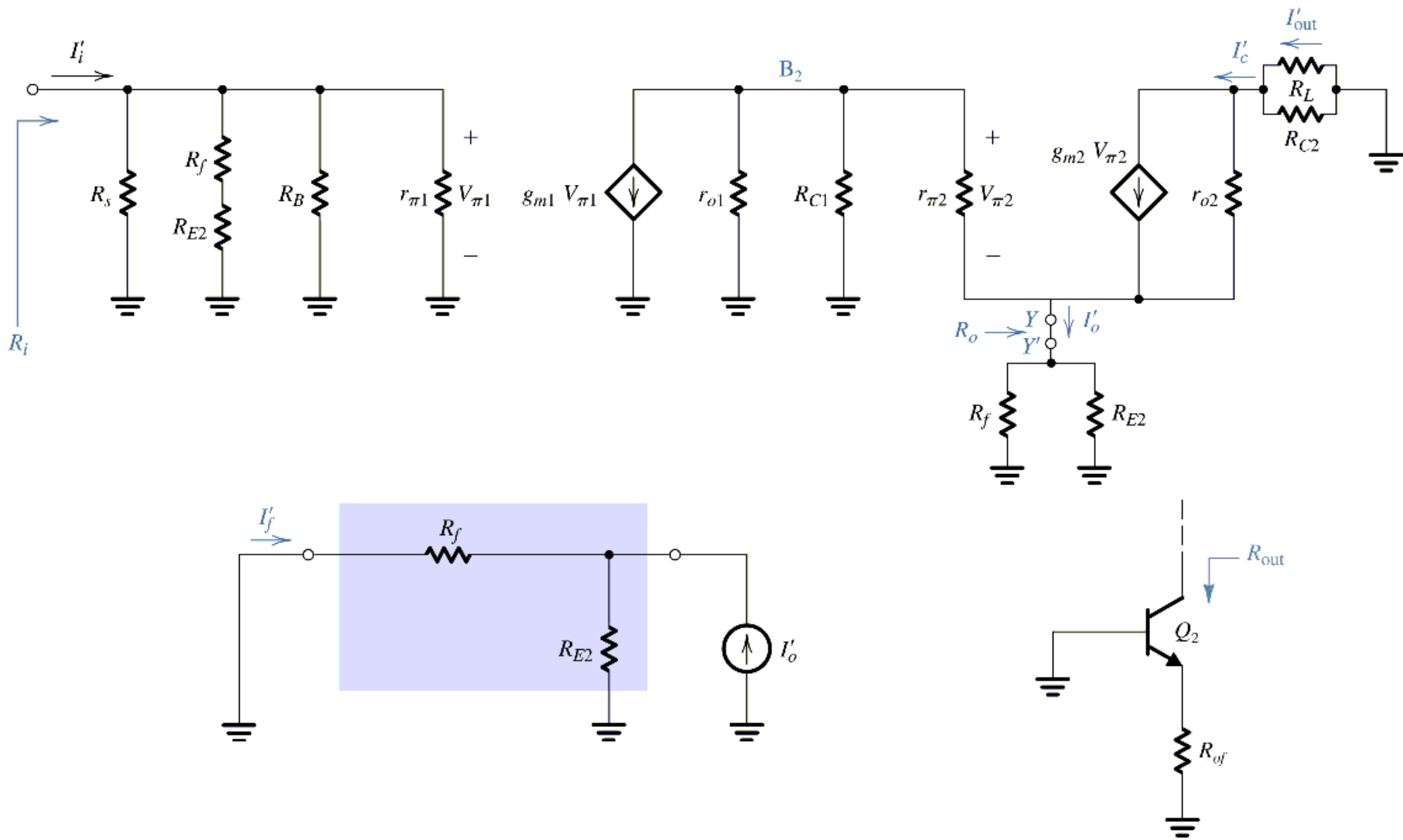

Fig. 8.25-2 Circuits for Example 8.4.



BOARD TESTER

Mehanicka povratna sprega

Fig. 12 - Bidirectional speed control of DC motor (Compensation networks not shown)

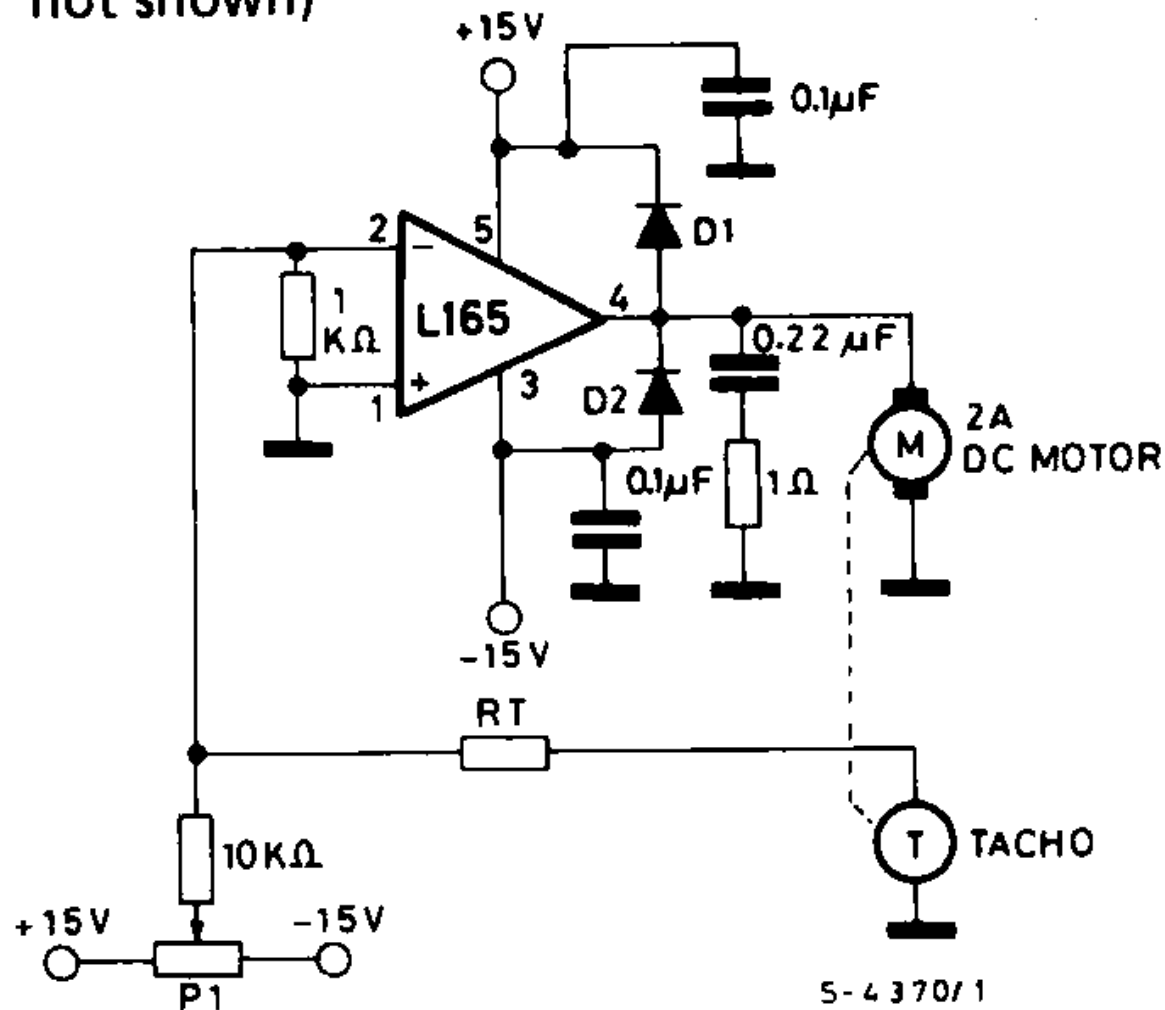

Transformatorska sprega sa modulatorom i demodulatorom

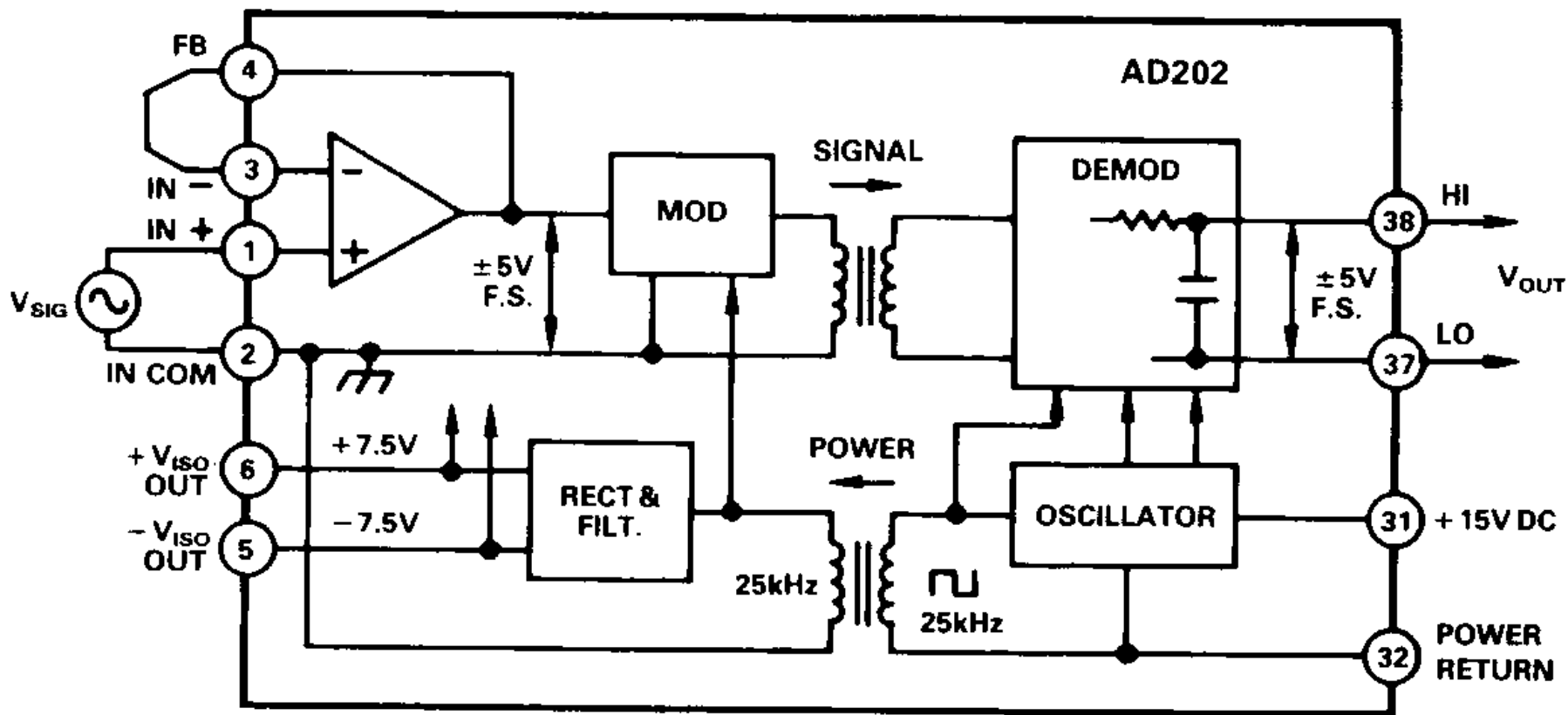

Figure 1a. AD202 Functional Block Diagram

Opticka sprega (pomocu laserskog zraka)

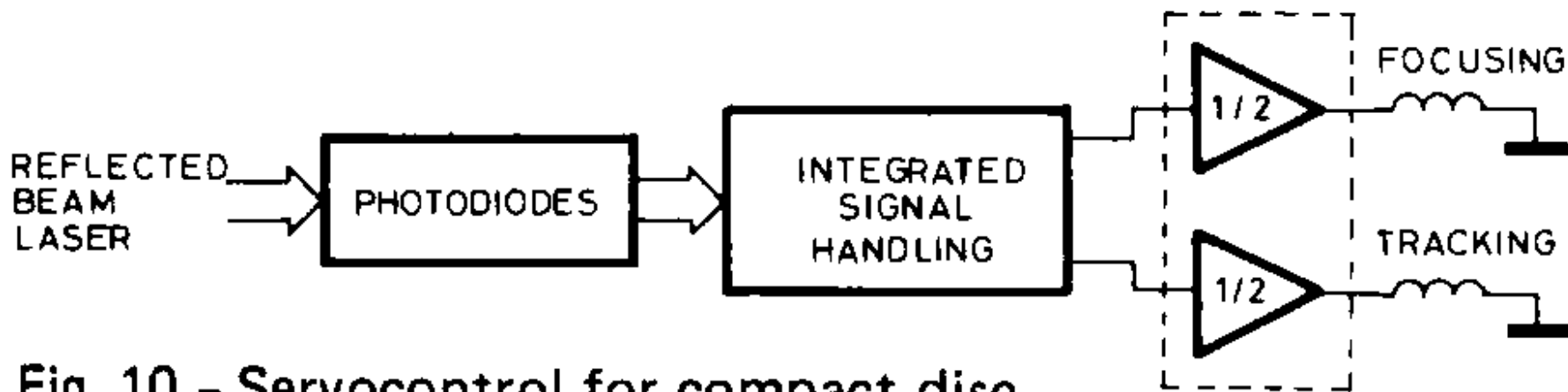

Fig. 10 - Servocontrol for compact-disc

Sprega pomocu Holove sonde

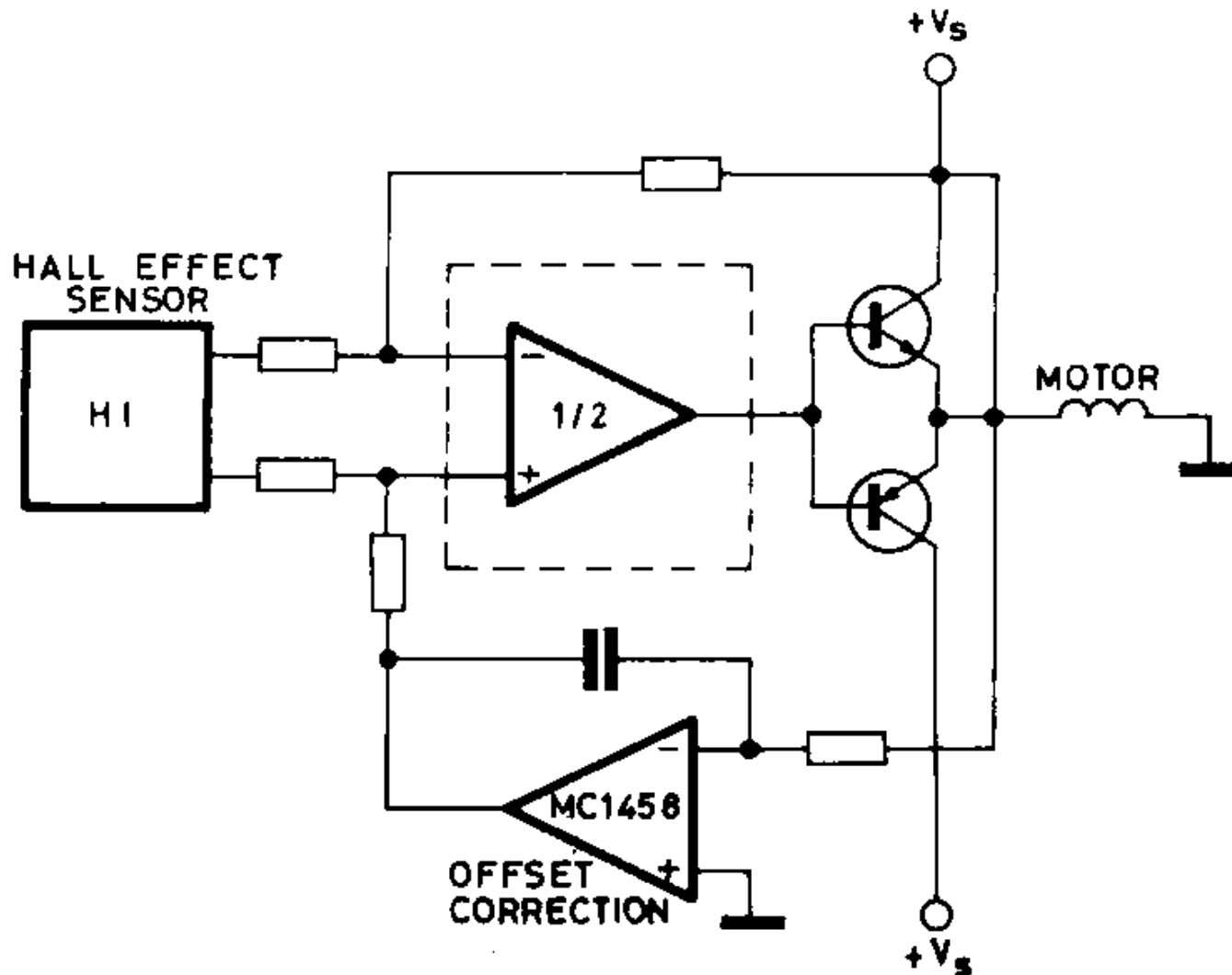
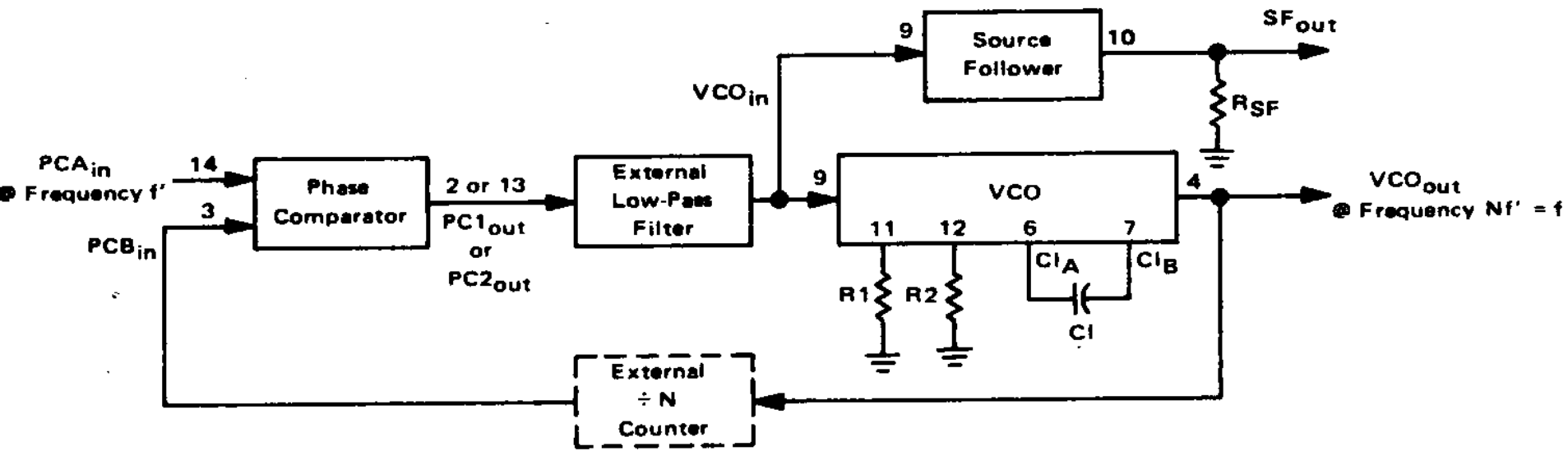

Fig. 11 - Compact-disc motor driver (1/2 section)

PLL = Fazno zatvorena petlja

FIGURE 3 – GENERAL PHASE-LOCKED LOOP CONNECTIONS AND WAVEFORMS



Typical Low-Pass Filters

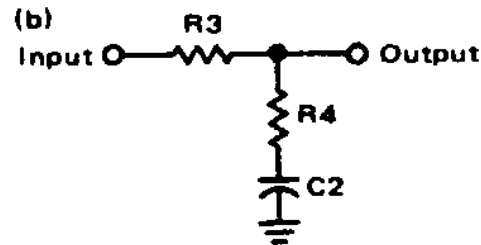
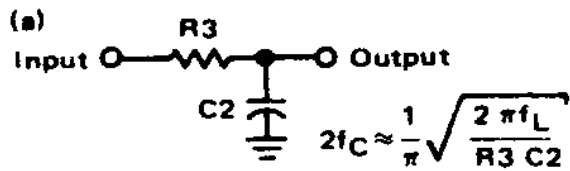

Typically:

$$R4 C2 = \frac{6N}{f_{max}} - \frac{N}{2\pi \Delta f}$$

$$(R3 + 3,000\Omega) C2 = \frac{100N\Delta F}{f_{max}^2} - R4 C2$$

$$\Delta f = f_{max} - f_{min}$$

Razne vrste signala i povratnih sprega

- Termicka - kod termoregulatora
- Force balance - kod vaga
- vlaga - kod regulatora vlage
- osvjetljaj - kod regulatora rasvjete
- kiselost - kod pH regulatora
- brzina fluida - kod regulatora protoka
- tezina ili duzina - kod regulatora nivoa
-

Različit pristup (ima i pogrešnih)

- https://en.wikipedia.org/wiki/Negative-feedback_amplifier
- <https://www.electronics-tutorials.ws/systems/negative-feedback.html>
- <https://learnabout-electronics.org/Amplifiers/amplifiers30.php>
- <https://www.electrical4u.com/what-is-an-oscillator/>

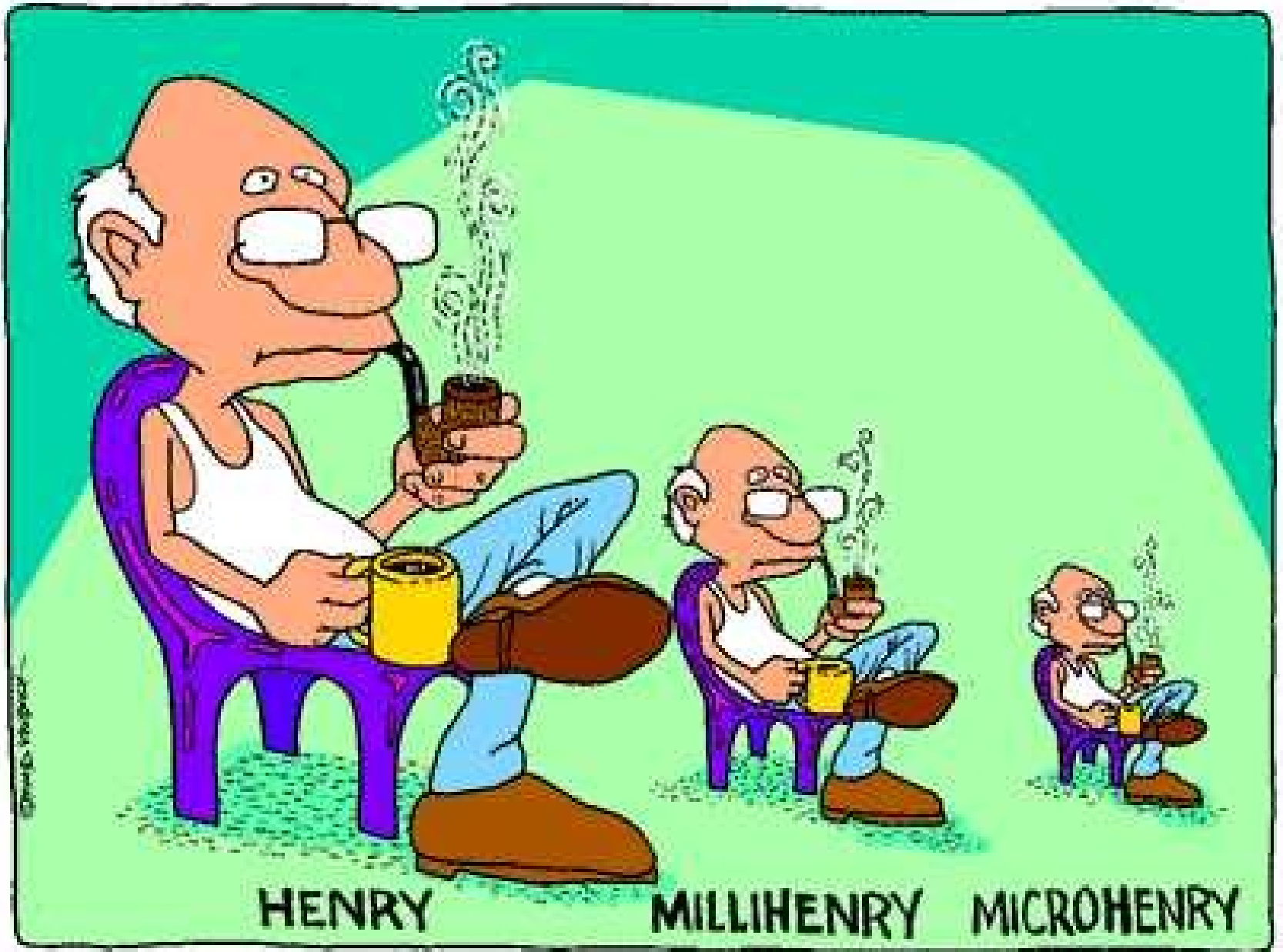

HENRY

MILLIHENRY

MICROHENRY

Nalazenje A i A_b presjecanjem
kružne konture

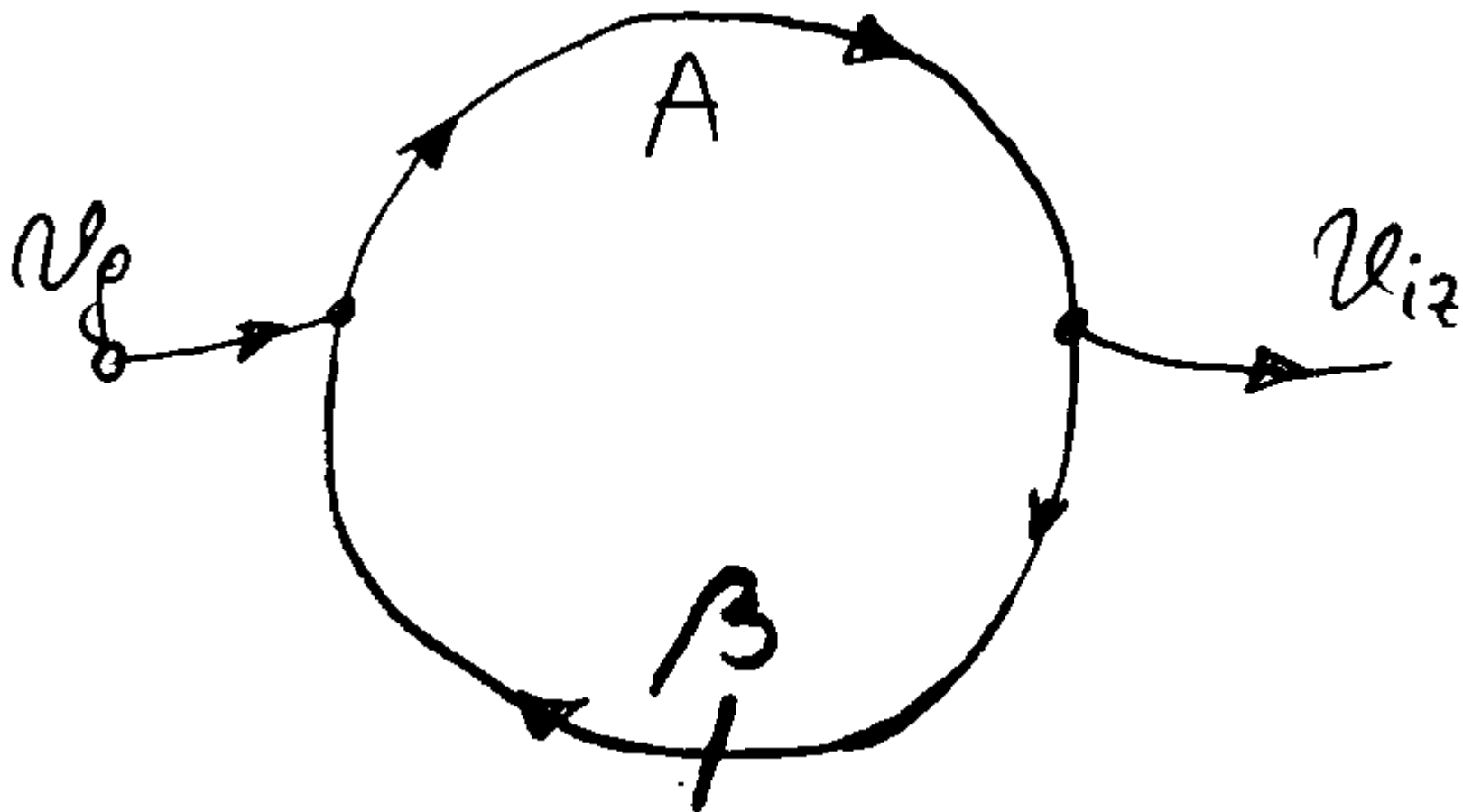

Modifikacija kola nakon presjecanja

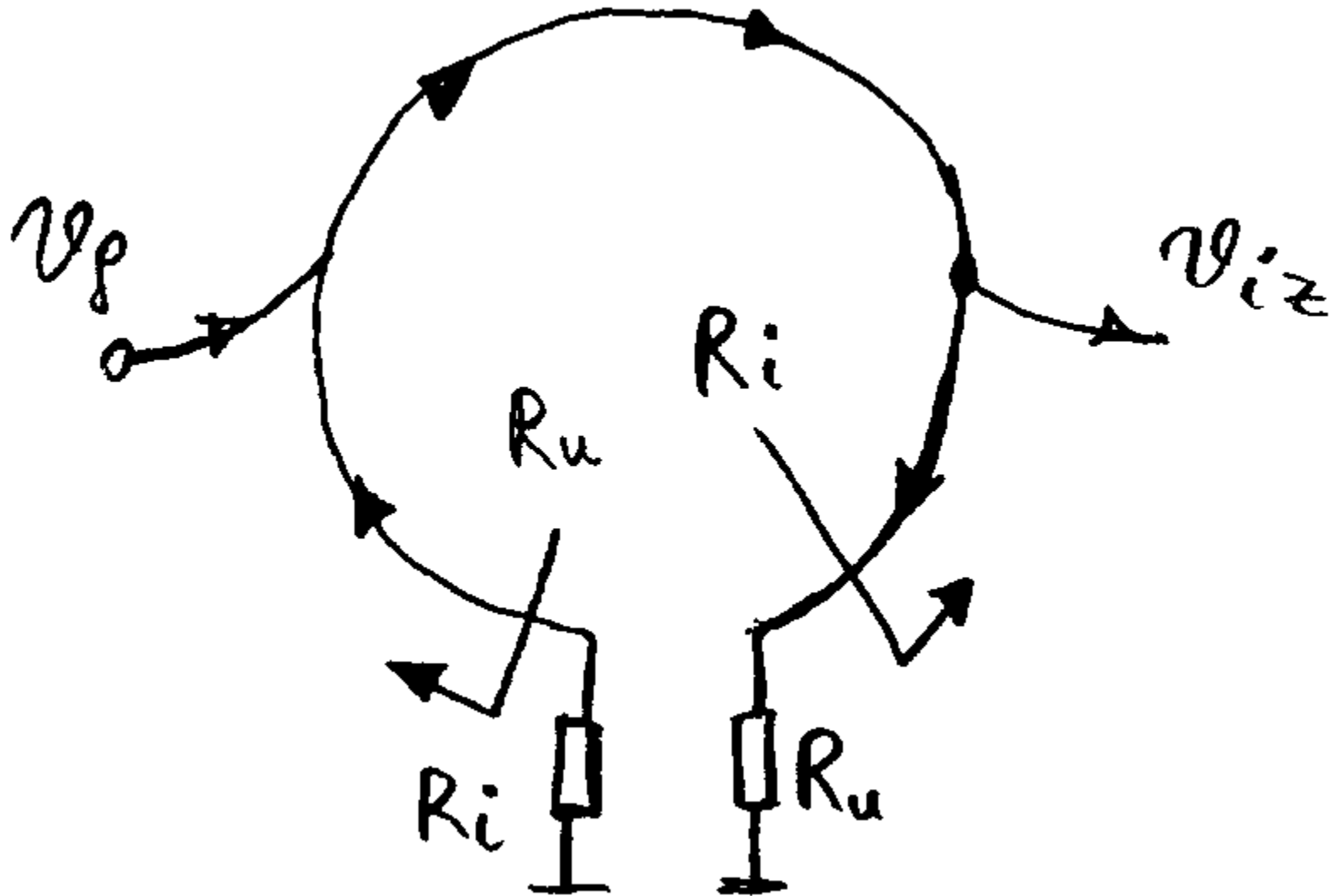

Nalazenje A_β pomocu naponskog testnog generatora (V_t)

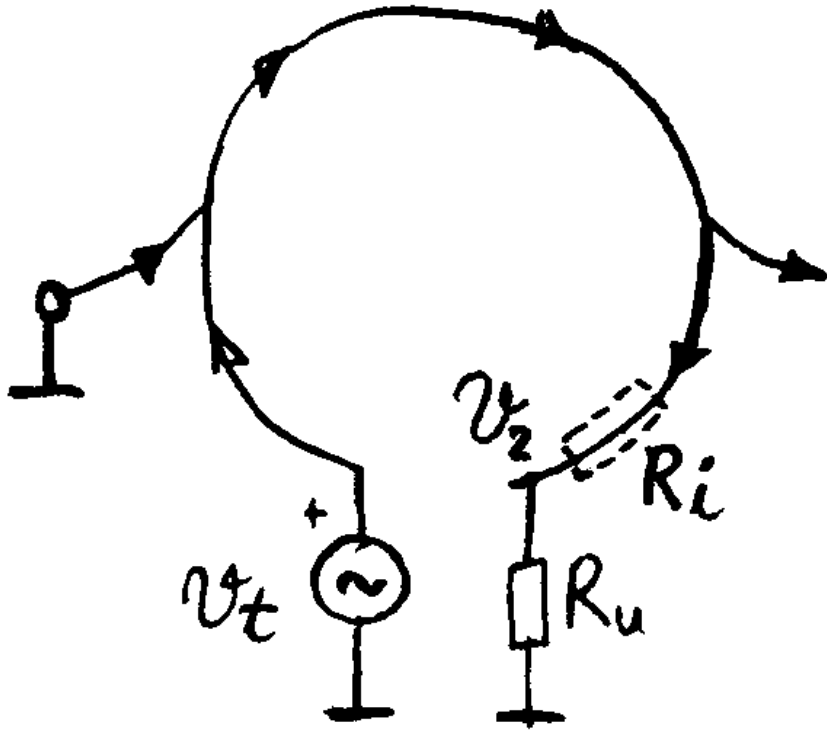

$$A_\beta = \frac{V_2}{V_t}$$

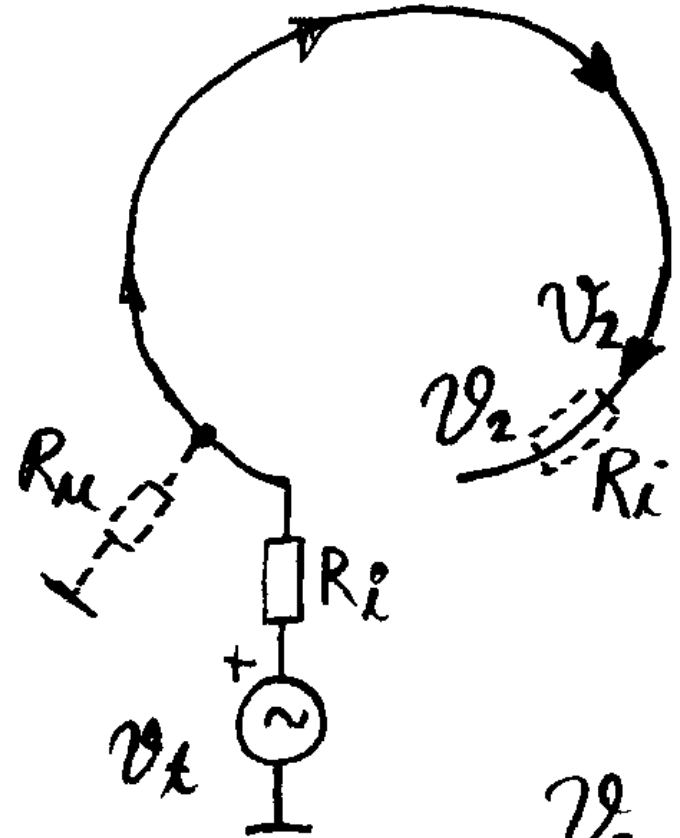

$$A_\beta = \frac{V_2}{V_t}$$

Nalazenje A_{β} pomocu strujnog testnog generatora (I_t)

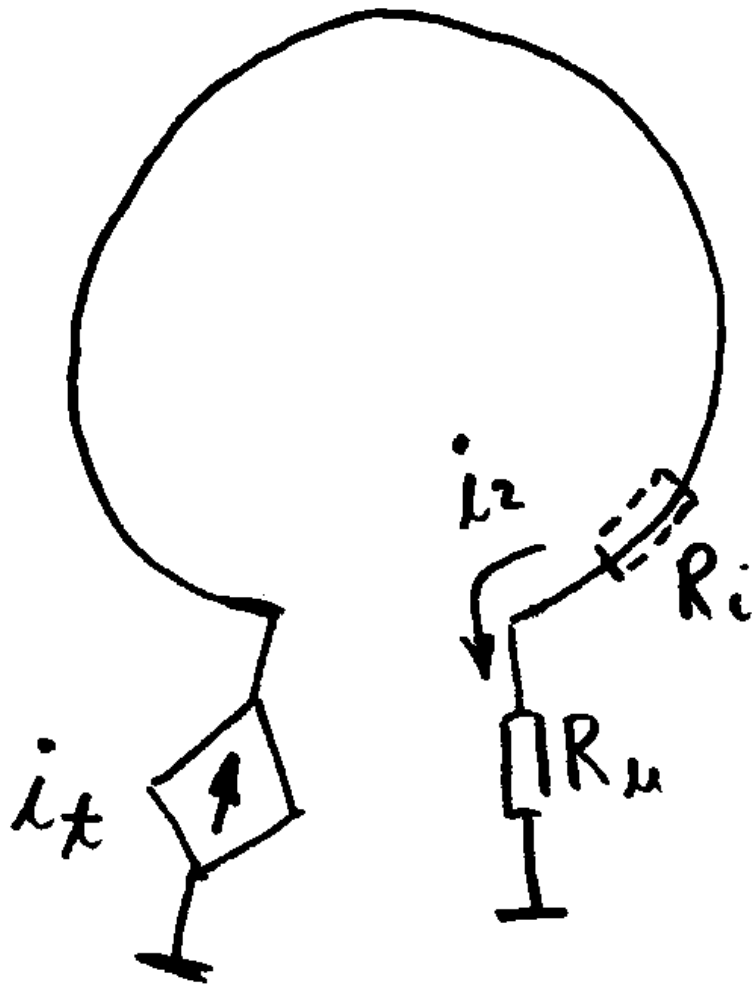

$$A_{\beta} = \frac{i_2}{i_t}$$

Nalazenje A_{β} pomocu I_t na drugi nacin (kratkospojen izlaz)

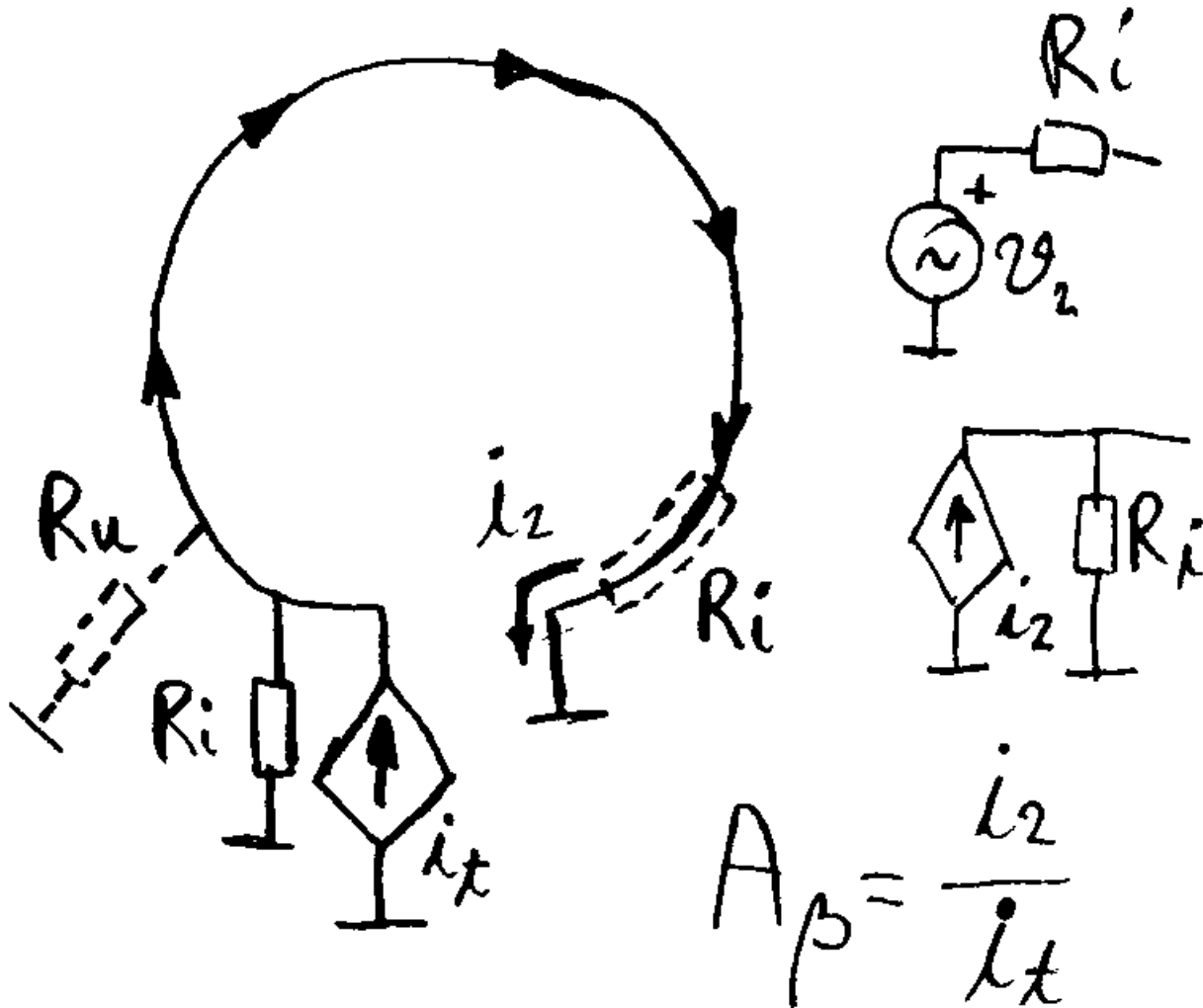

Ako se kontura presjece na pogodnom mjestu, modifikacija kola može biti veoma jednostavna

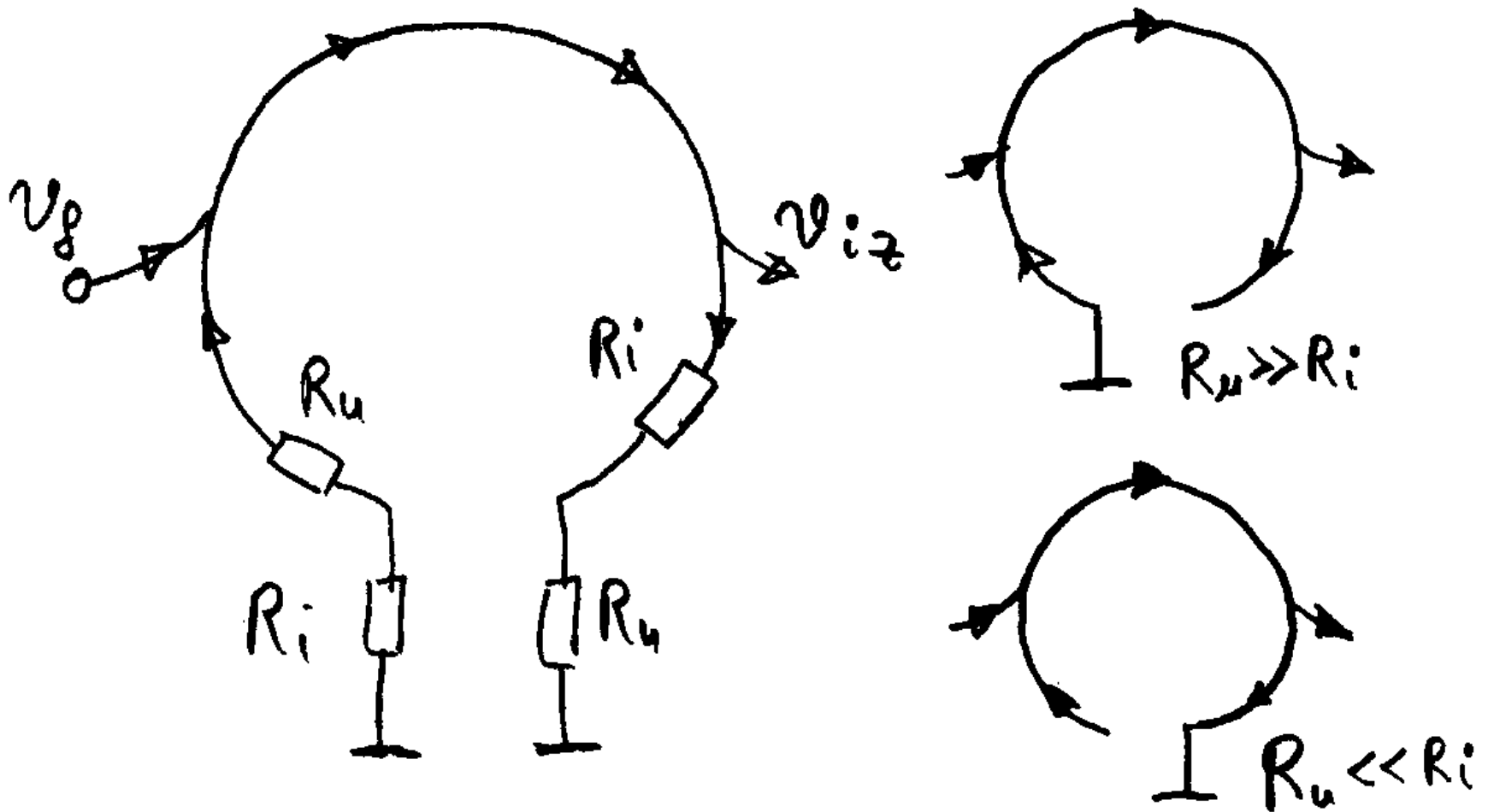

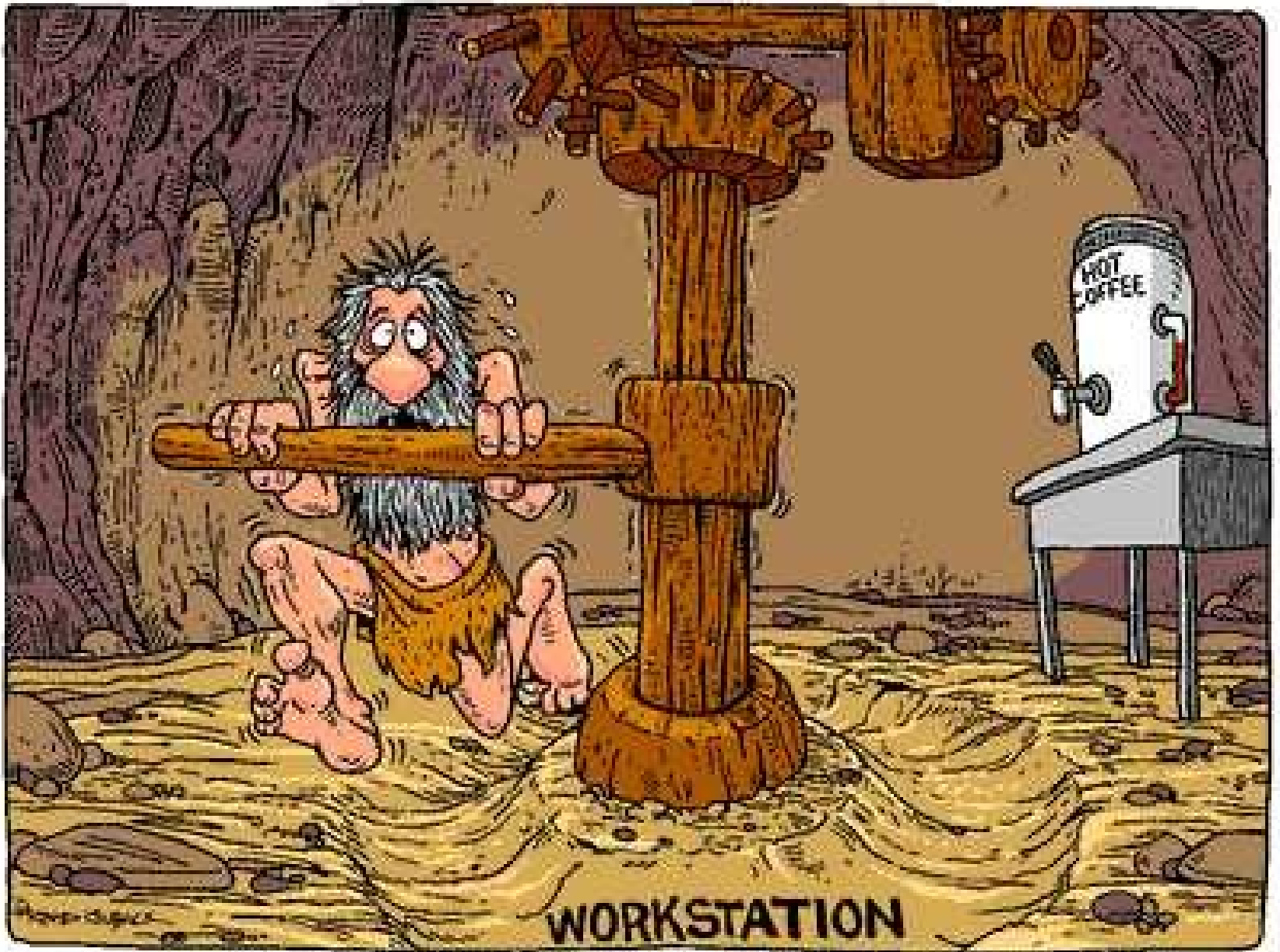

WORKSTATION

NPS smanjuje uticaj nelinearnosti direktne grane

Sve neprecizne, nelinearne, nestabilne elemente stavljamo u direktnu granu, a precizne i stabilne u povratnu granu

$$I_c = I_s e^{V_{BE}/V_T}$$

$$I_D = B (V_{GS} - V_{GST})^2$$

$$I_D = I_0 (e^{V_D/V_T} - 1)$$

$$A_n = \frac{A}{1 - A\beta}$$

$$|A\beta| \gg 1 \Rightarrow A_n = \frac{1}{-\beta}$$

Dobijanje inverznih funkcija pomocu NPS

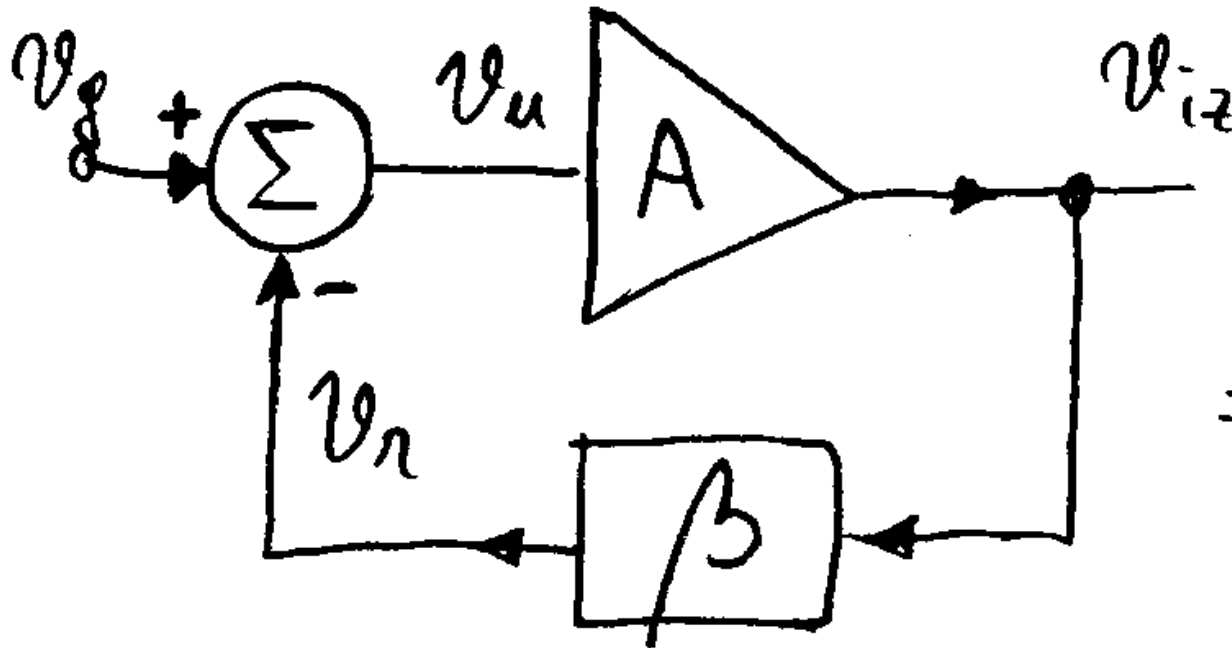

$$\begin{aligned} & A \rightarrow \infty \\ \Rightarrow & v_u \rightarrow 0 \\ \Rightarrow & v_n = v_g \\ & v_n = \beta(v_{iz}) \\ & v_g = \beta(v_{iz}) \end{aligned}$$

$$\Rightarrow v_{iz} = \beta^{-1}(v_g)$$

Uticaj NPS na AFK i FFK

$$A_n = \frac{A}{1 - A_\beta} = \begin{cases} A & ; |A_\beta| \ll 1 \\ & ; |A| \ll \left| \frac{1}{\beta} \right| \\ -\frac{1}{\beta} & ; |A_\beta| \gg 1 \\ & ; |A| \gg \left| \frac{1}{\beta} \right| \end{cases}$$

AFK od A_r se dobija kada se uzima manja AFK od: A i $1/\beta$

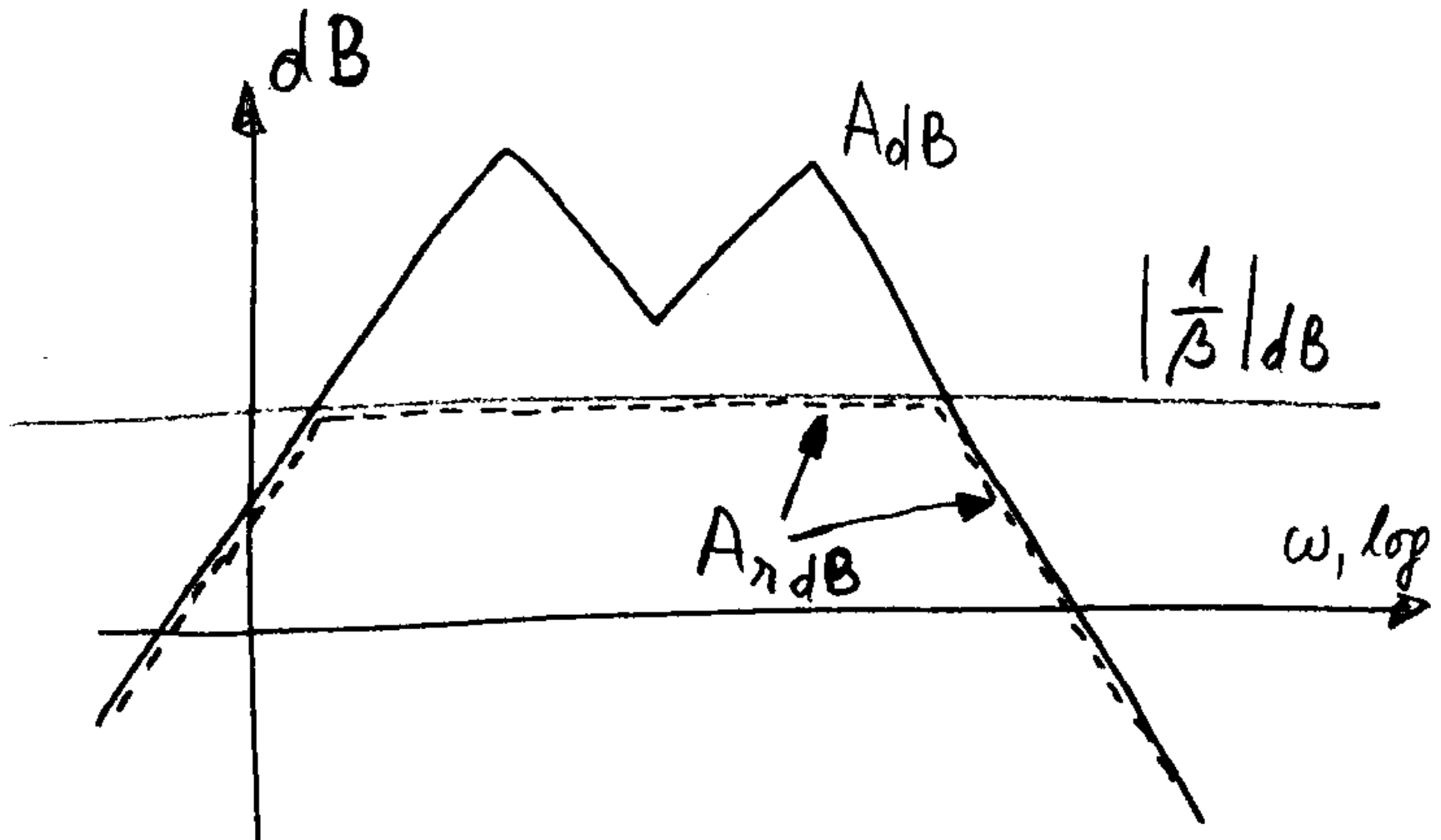

Ne moramo da znamo koliko je β , niti šta je sve uključeno u β .

Postupak je sledeći:

- 1) Uočimo direktnu i povratnu grane kola.
- 2) Računamo asimptotu prenosne funkcije za slučaj da je $A\beta \gg 1$.
Zatvorimo petlju i računamo kao da je A beskonačno ($A \rightarrow \infty$). Drugim riječima, računamo kao da imamo idealne OP.
- 3) Računamo asimptotu prenosne funkcije za slučaj da je $A\beta \ll 1$.
Prekinemo povratnu granu ($\beta=0$) i nađemo pojačanje direktne grane.
Ono se još zove pojačanje u otvorenoj petlji A_{OL} (open loop gain).
- 4) Na kraju uzimamo od obje asimptote onaj dio koji je manji.

Primjer 1 – neinvertujući pojačavač sa OP (fg=40Hz i ft=1MHz)

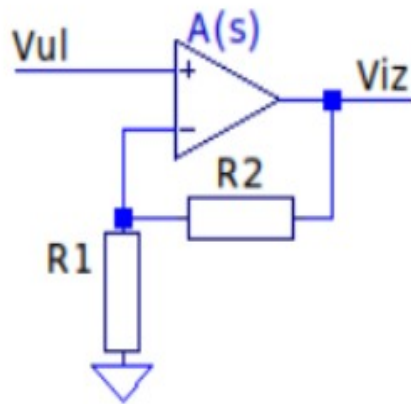

$$A\beta \gg 1; A \rightarrow \infty$$

$$V_{iz}/V_{u1} = 1 + R2/R1$$

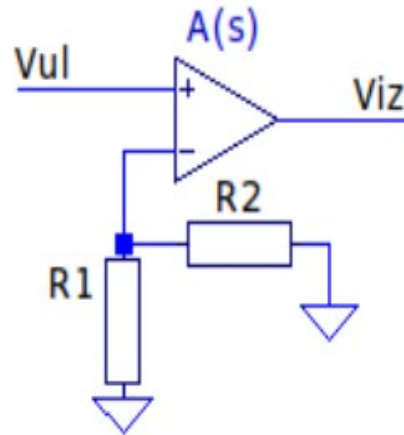

$$A\beta \ll 1; \beta = 0$$

$$V_{iz}/V_{u1} = A(s)$$

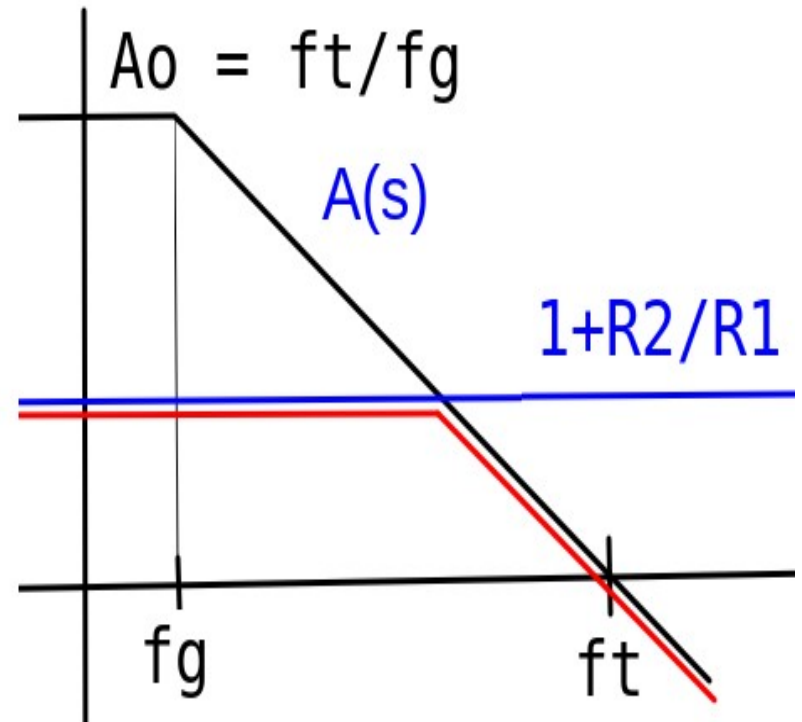

Primjer uticaja NPS na AFK kod LM741

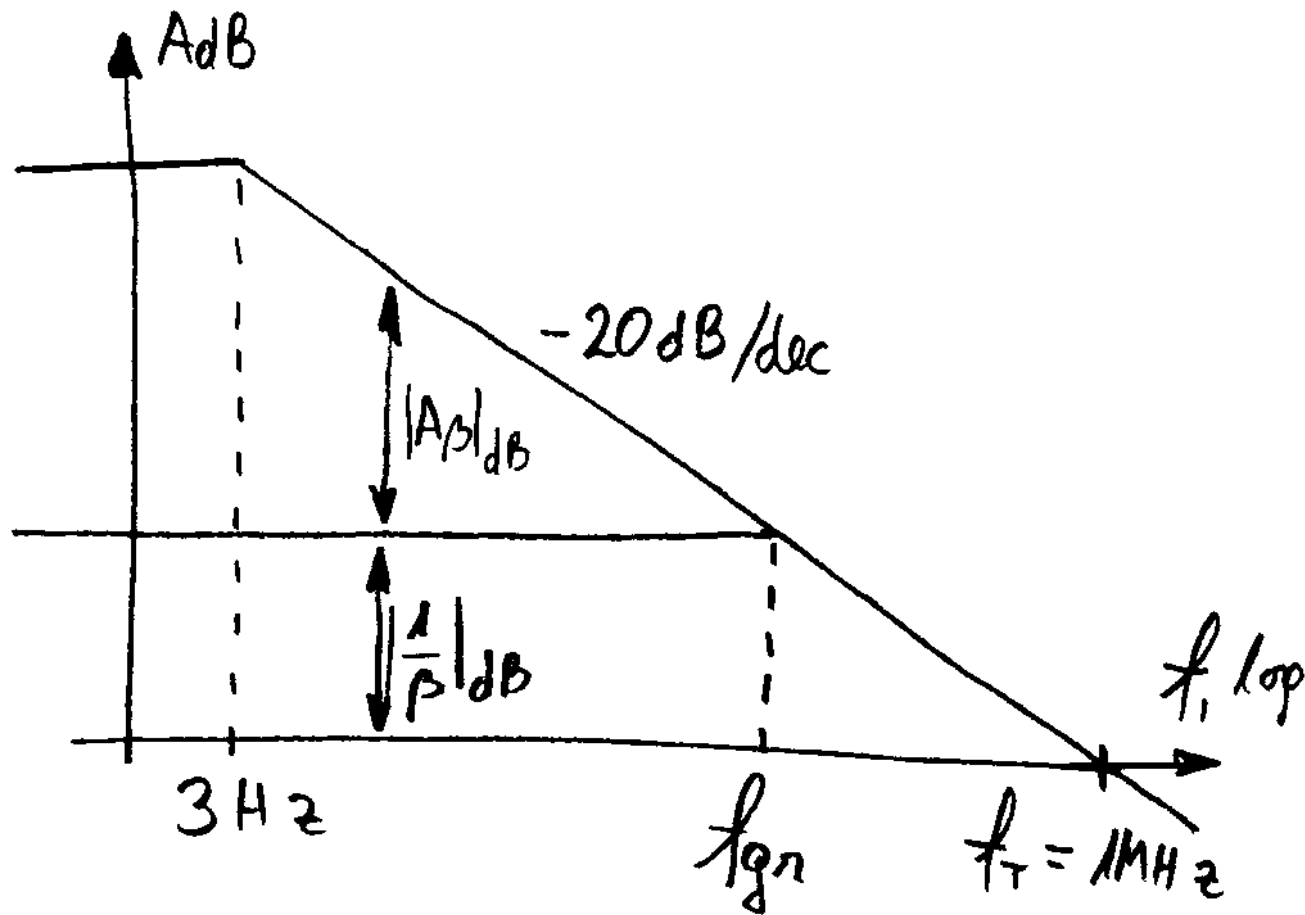

$$A_n \cdot f_{gn} = \text{GBWP} = f_T$$

Primjer 2

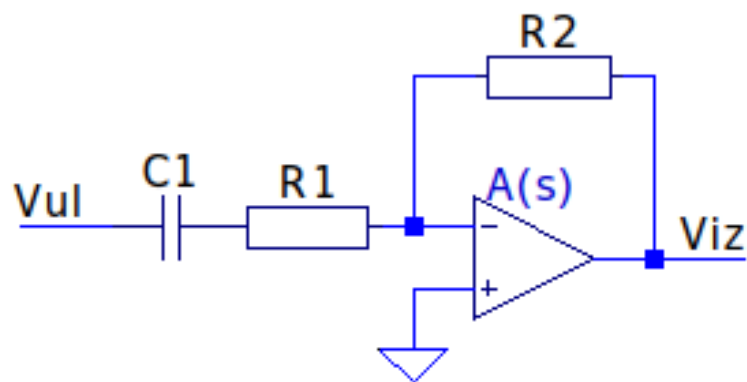

$$A\beta \gg 1; A \rightarrow \infty$$

$$V_{iz}/V_{u1} = -R2/(R1 + 1/sC1)$$

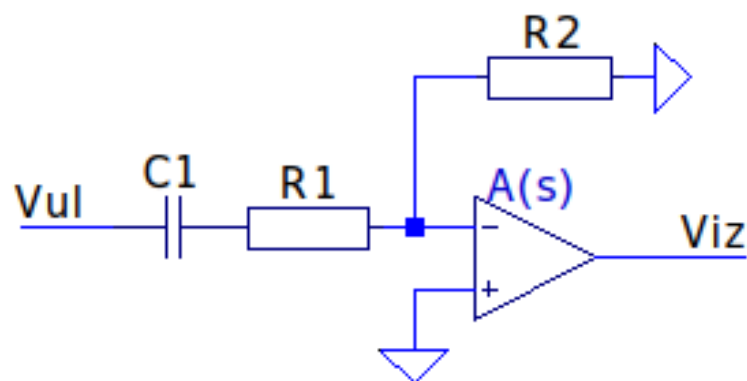

$$A\beta \ll 1; \beta = 0$$

$$V_{iz}/V_{u1} = R2/(R1 + R2 + 1/sC1) * (-A(s))$$

Nalazenje Ar kod kola sa NPS i direktnim granama van NPS

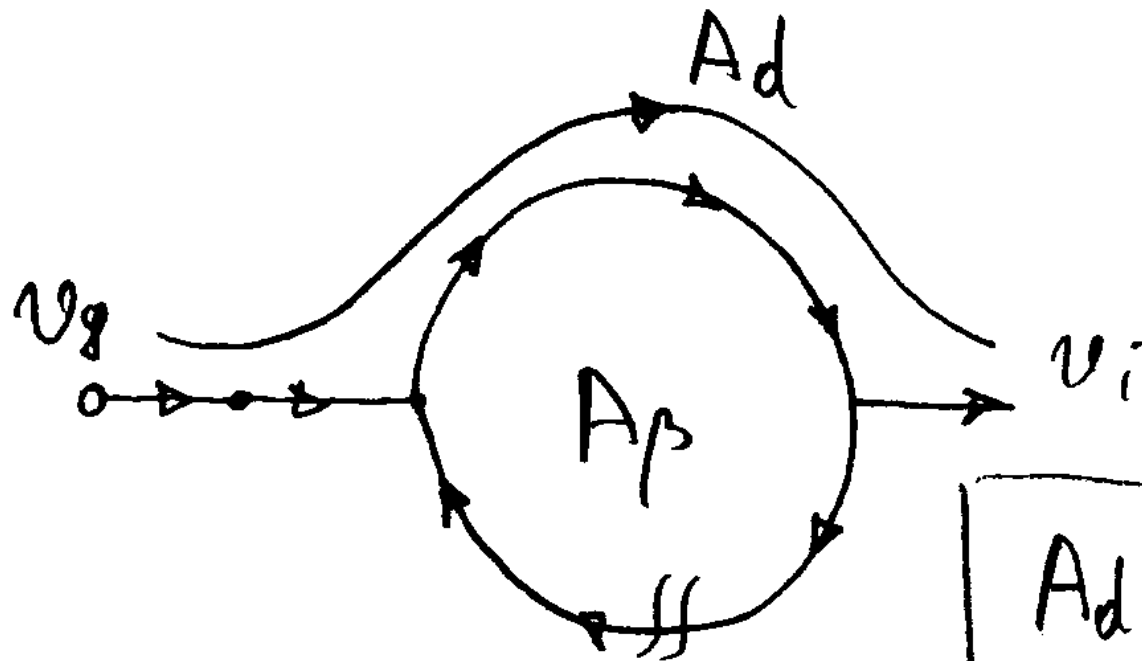

$$A_r = \frac{v_i}{v_g} = \frac{A_d}{1 - A_\beta}$$

$$A_d = \frac{v_i}{v_g}$$

уз отворању кондуку

A_β = кружно отјероње

Kolo sa dvije lokalne NPS

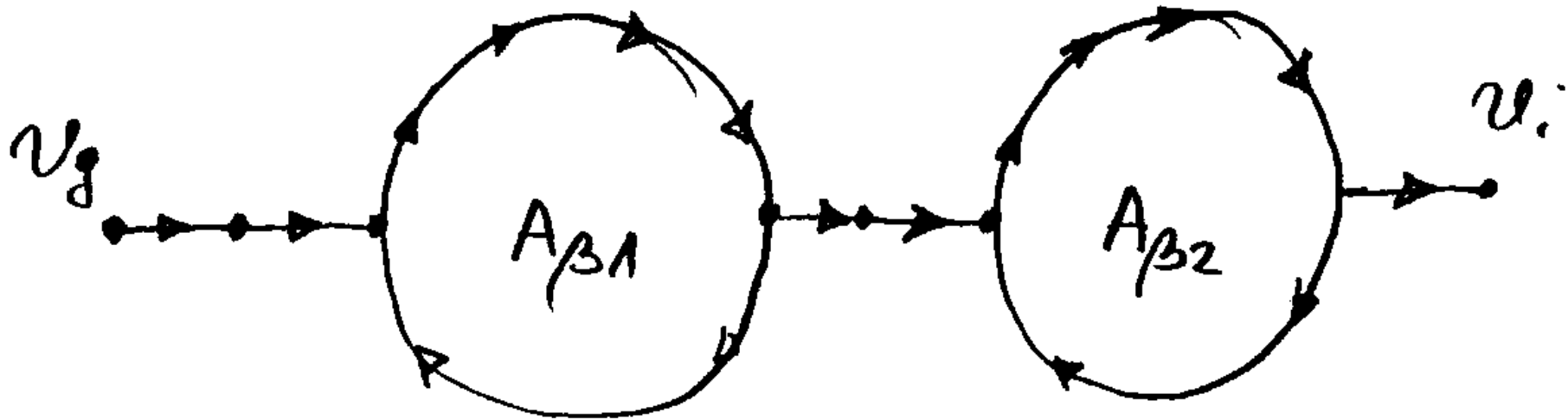

$$A_n = \frac{v_i}{v_g} = \frac{A_d}{(1 - A_{\beta 1})(1 - A_{\beta 2})}$$

Kako savijati nozice tranzistora

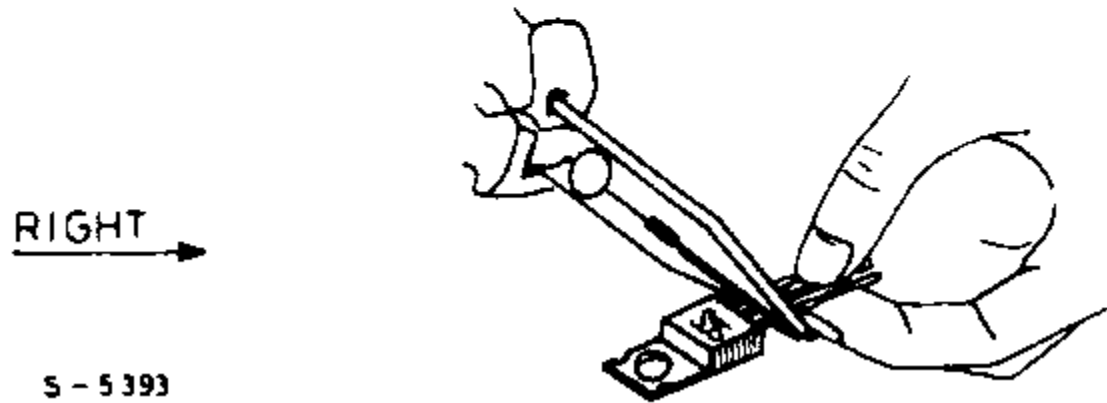
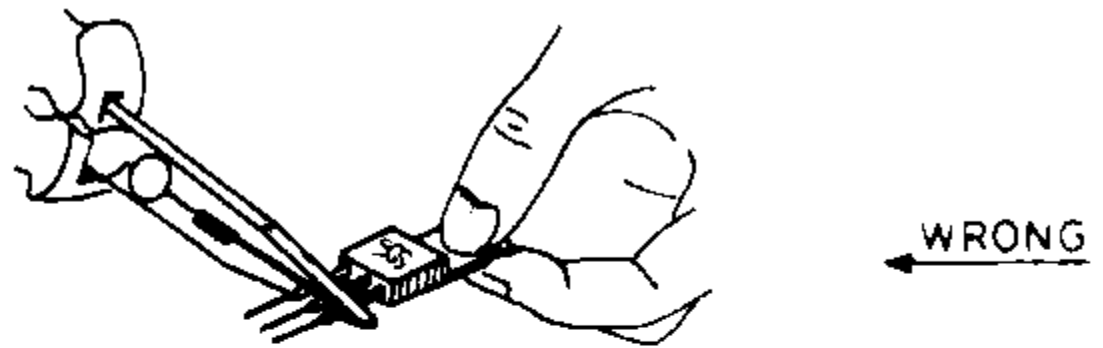

S - 5393

Savijajte bar 3mm dalje od kucista

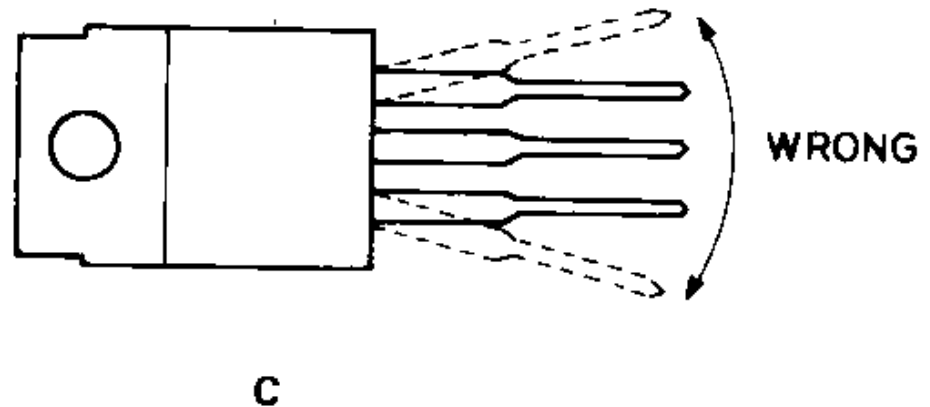
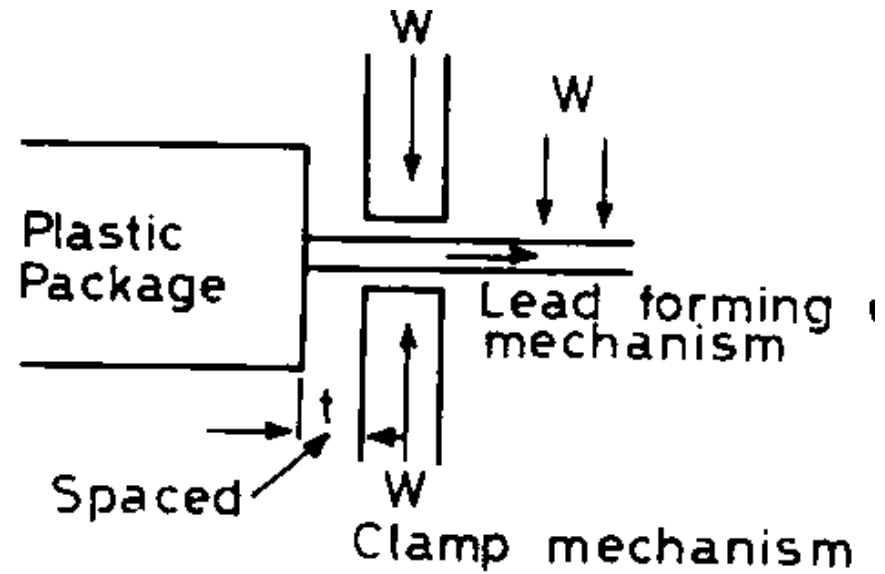
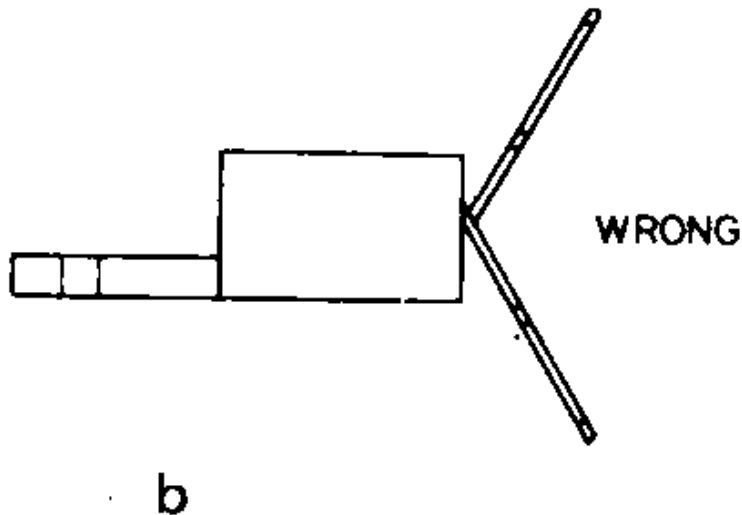
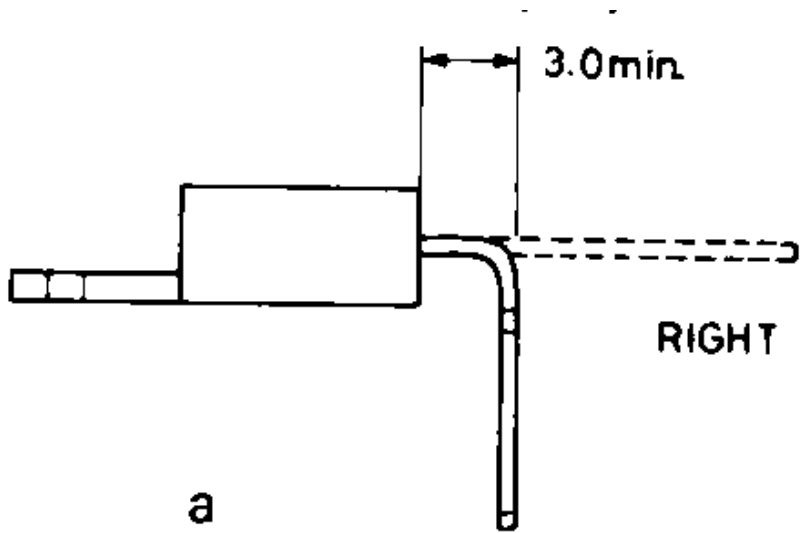

Teme u nastavku price o NPS:

- Uticaj NPS na ulazne, izlazne i ostale impedanse u kolu
- Uticaj NPS na izoblicenja i mrtve zone
- Primjer audio pojačavaca sa NPS
- Razna kola sa OP

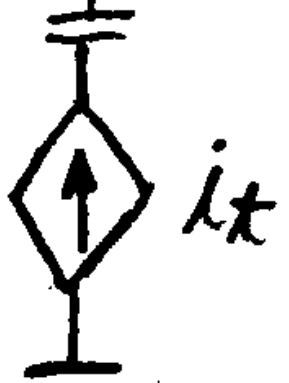
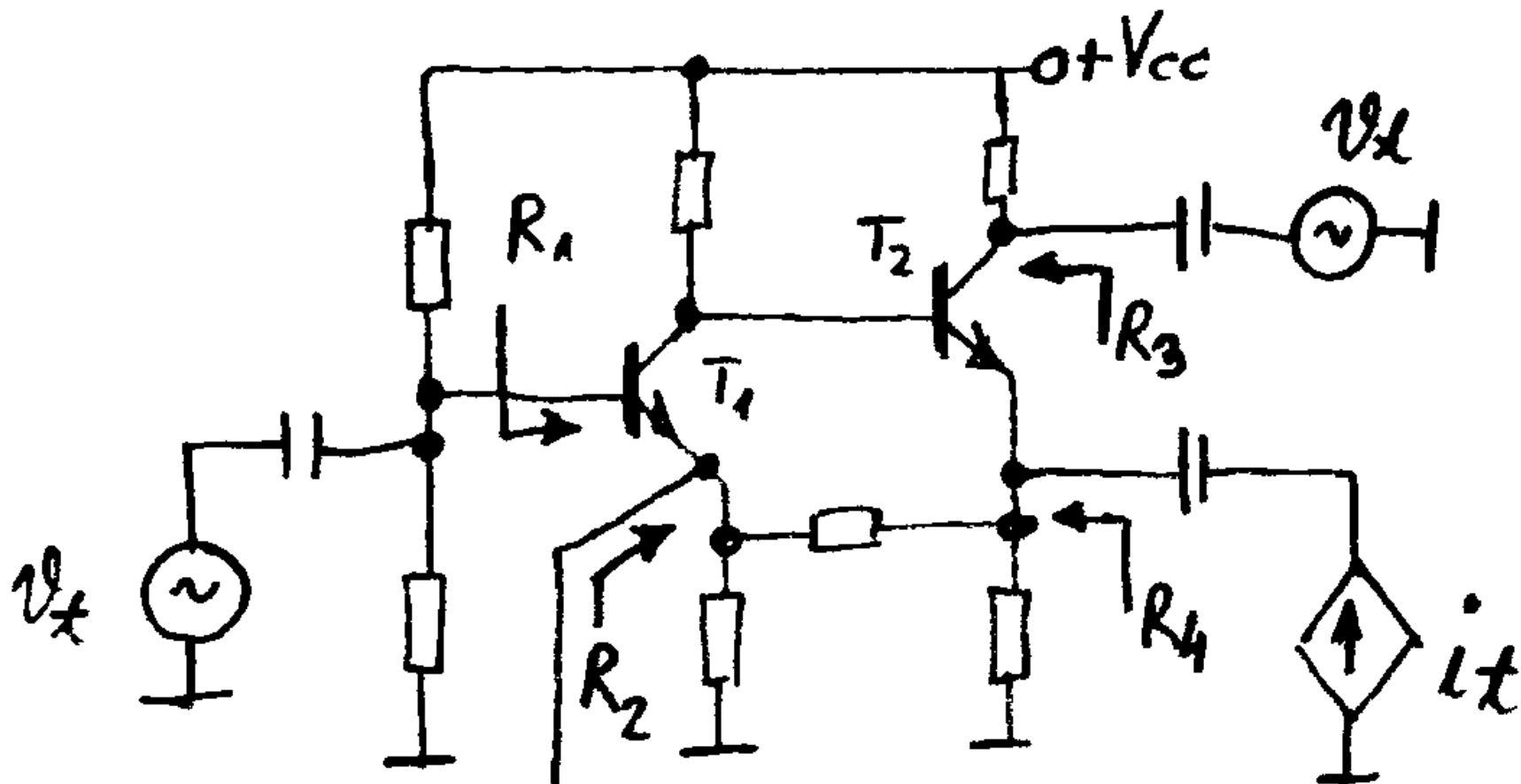

$$R_i = \frac{v_{st}}{i_{b1}}$$

$$R_{in} = \frac{v_{st}}{i_{b1n}}$$

NPS smanjuje impedanse na konturi, a povecava impedanse van konture.

$$R_{1n} = R_1 (1 - A_\beta); \quad R_{2n} = \frac{R_2}{1 - A_\beta}$$

$$R_{3n} = R_3 (1 - A_\beta); \quad R_{4n} = \frac{R_4}{1 - A_\beta}$$

Izoblicenje mrtve zone kod pojačavaca u B klasi

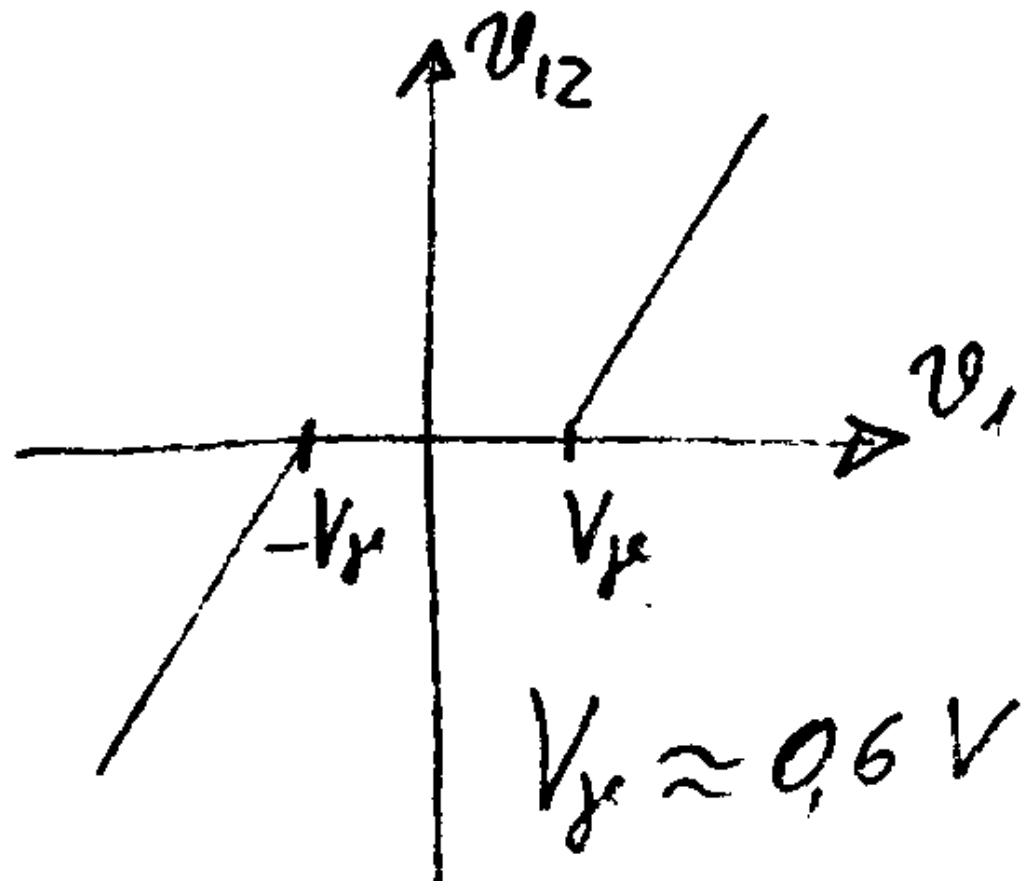
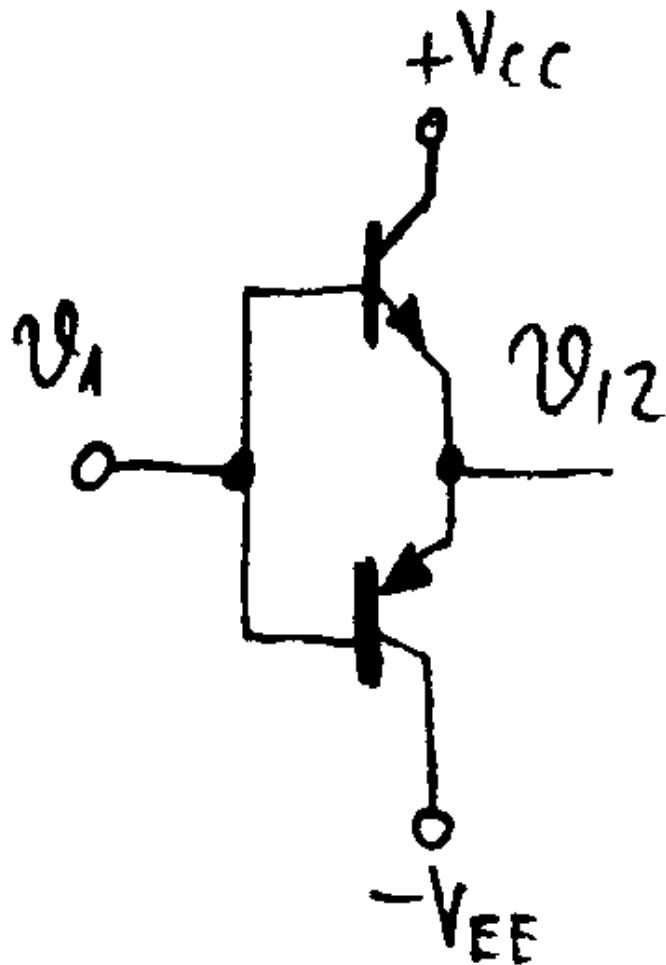

Izoblicenje zbog mrtve zone

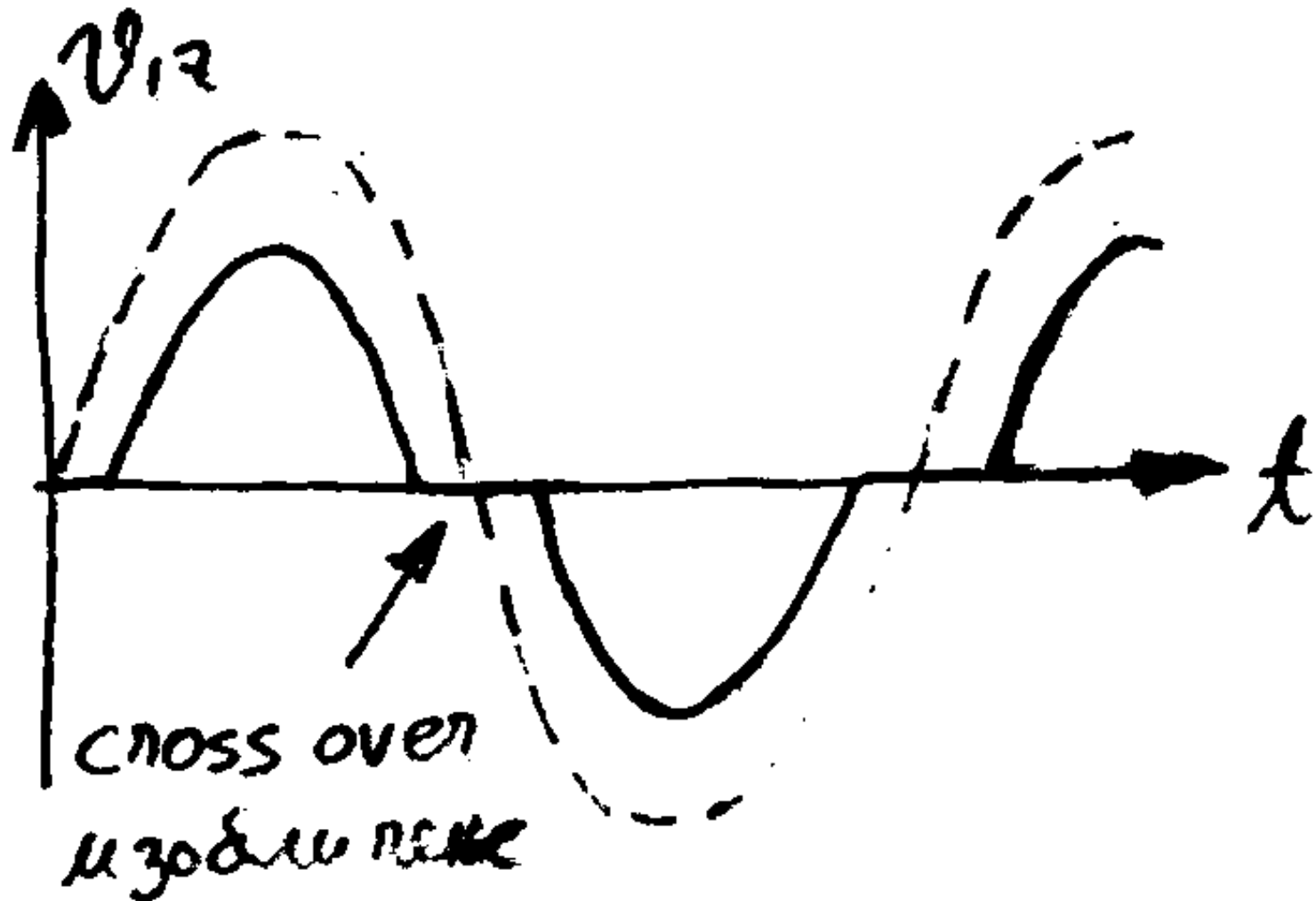

NPS smanjuje mrtvu zonu A puta

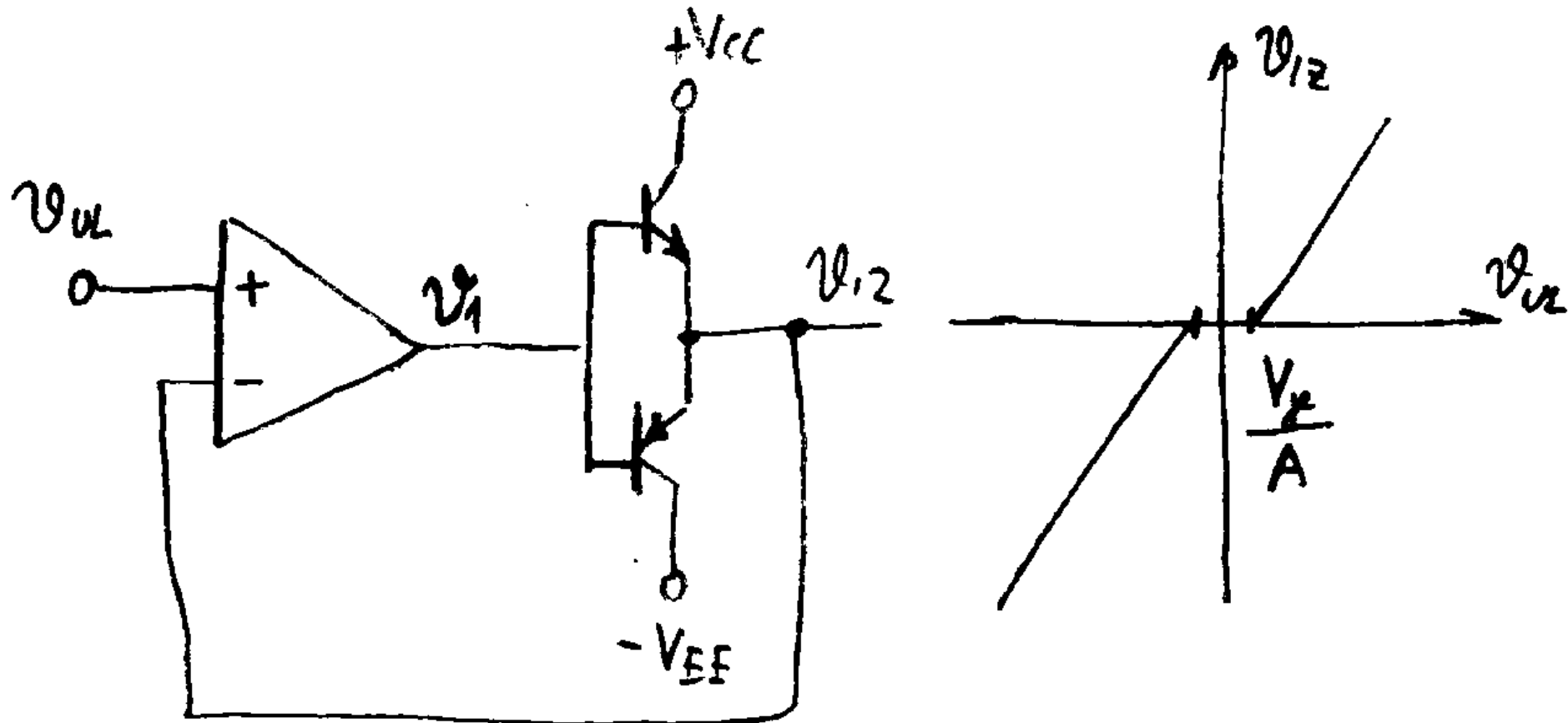

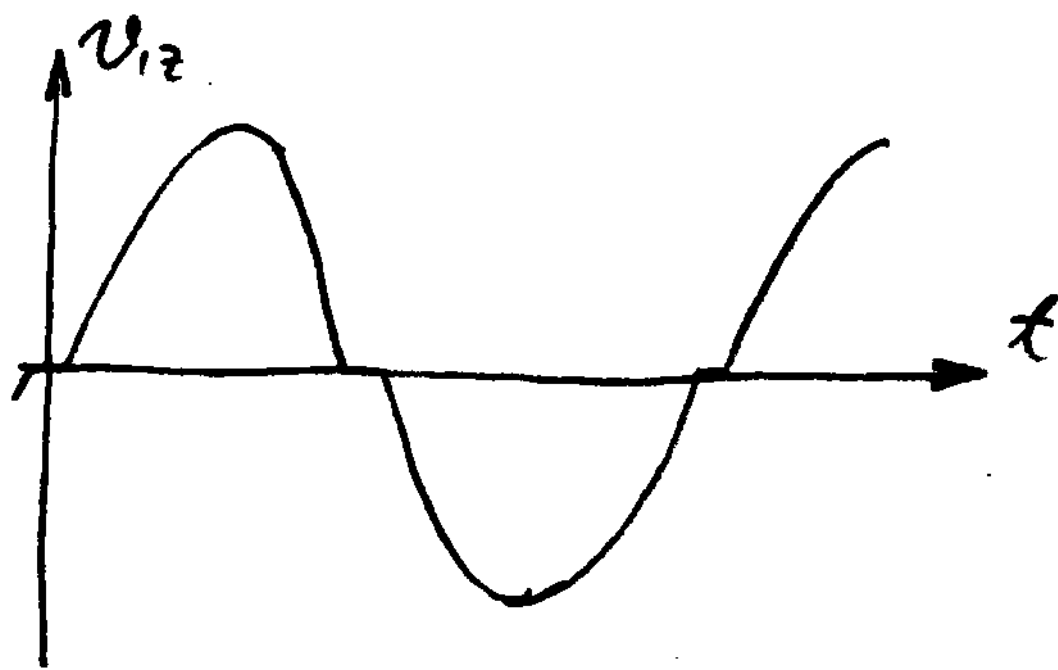

Zbog
ograničene
brzine
pojacavaca
(slew rate),
izoblicenja
će ipak
postojati bez
obzira na
NPS.

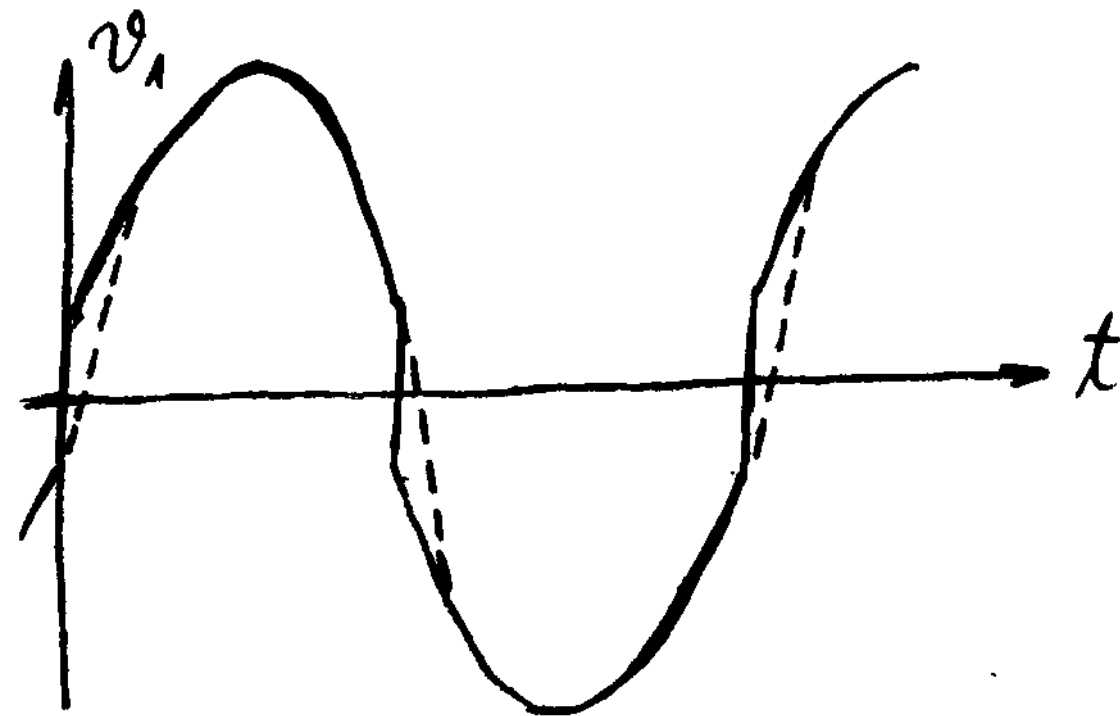

Koliko je A_v ovog pojačavaca?

Figure 11. Audio Amplifier

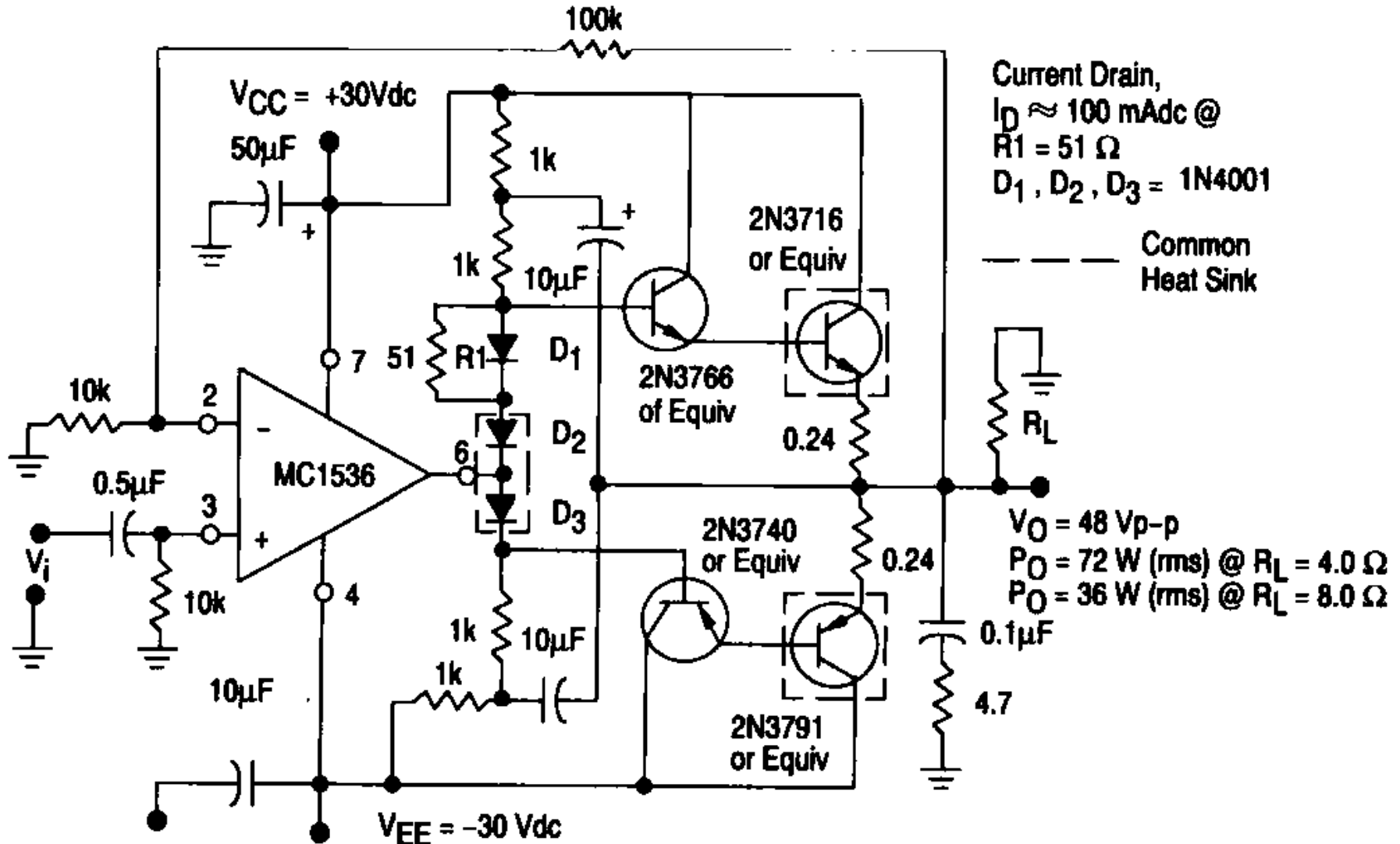



DIGITAL VOLTMETER

PIN CONNECTIONS

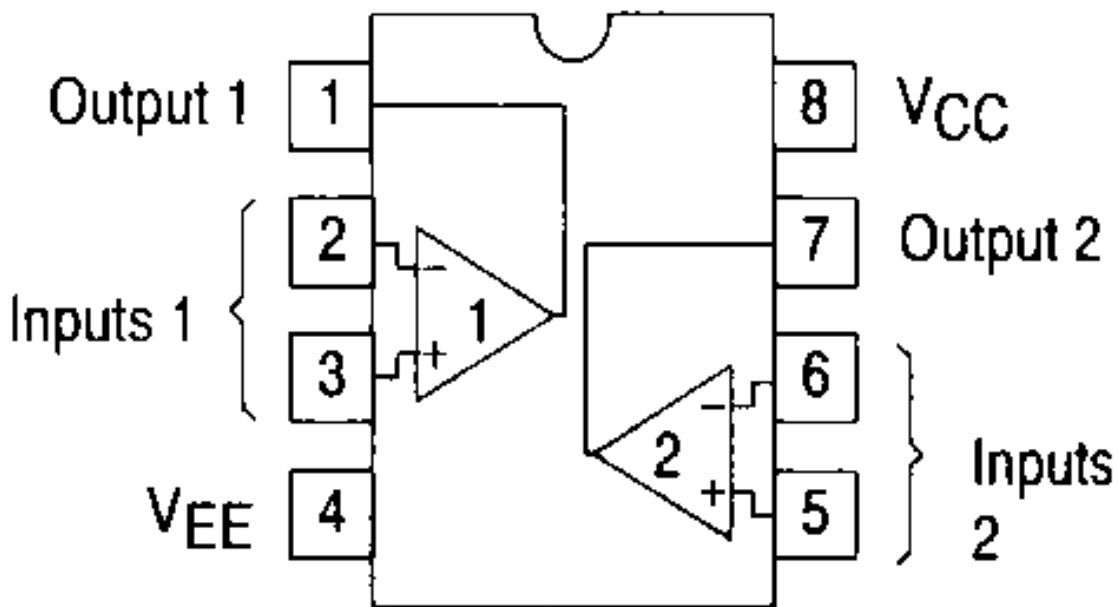

(Dual Package,
Top View)

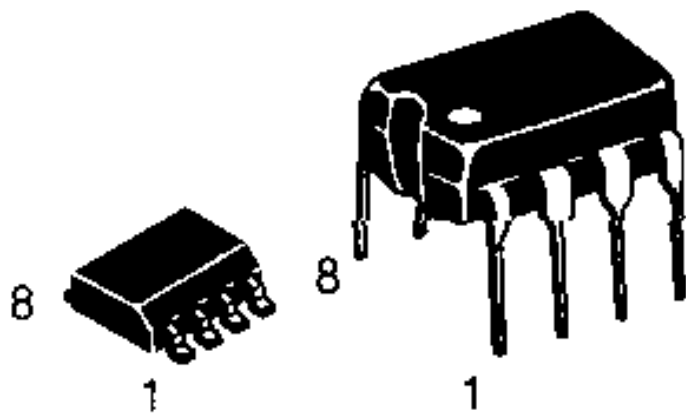

Sleep
Op.Amp.
Operacioni
pojacavac
koji spava

MC33102

Simplified Block Diagram

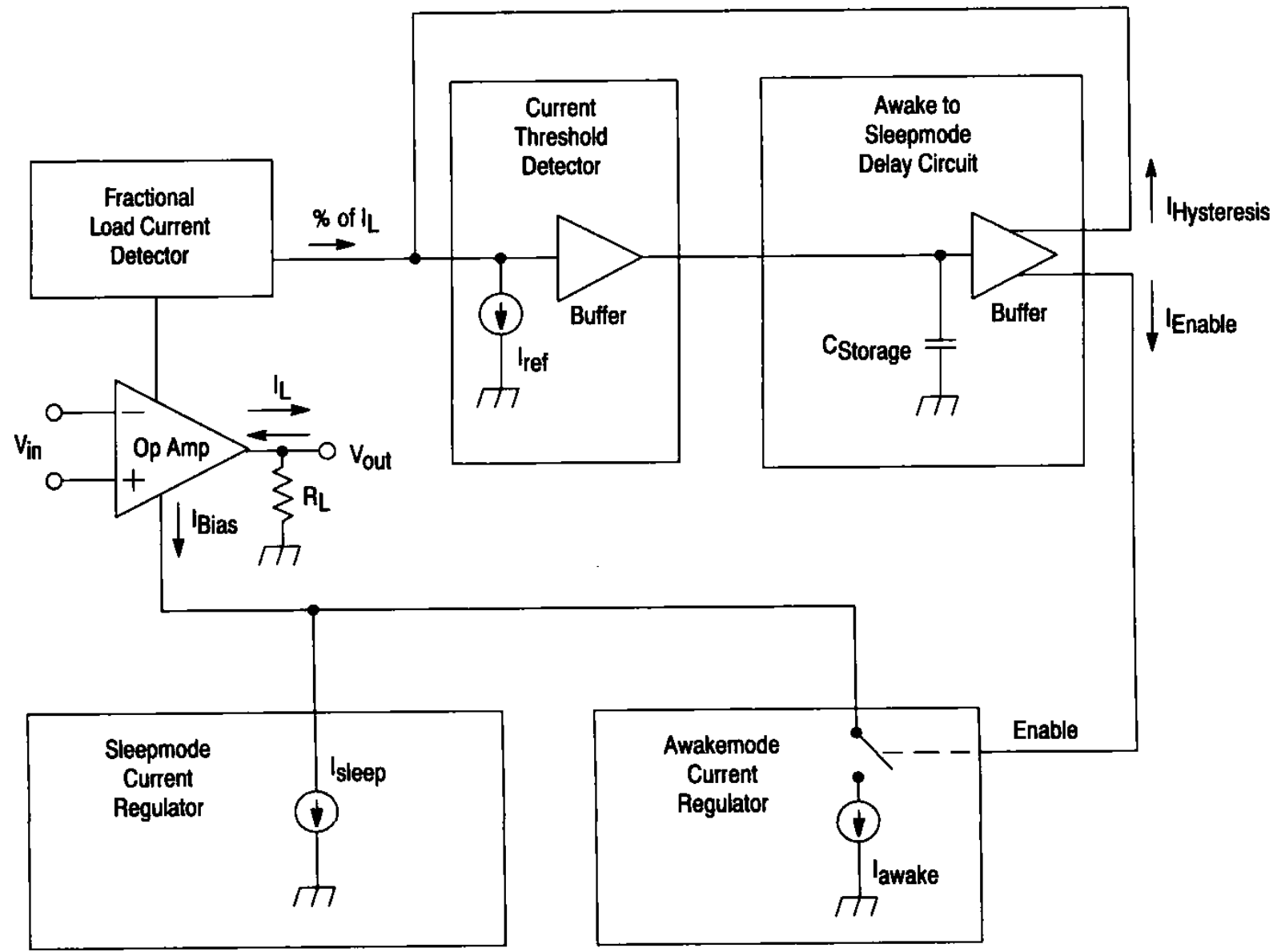

OP od sine do sine (Rail to rail)

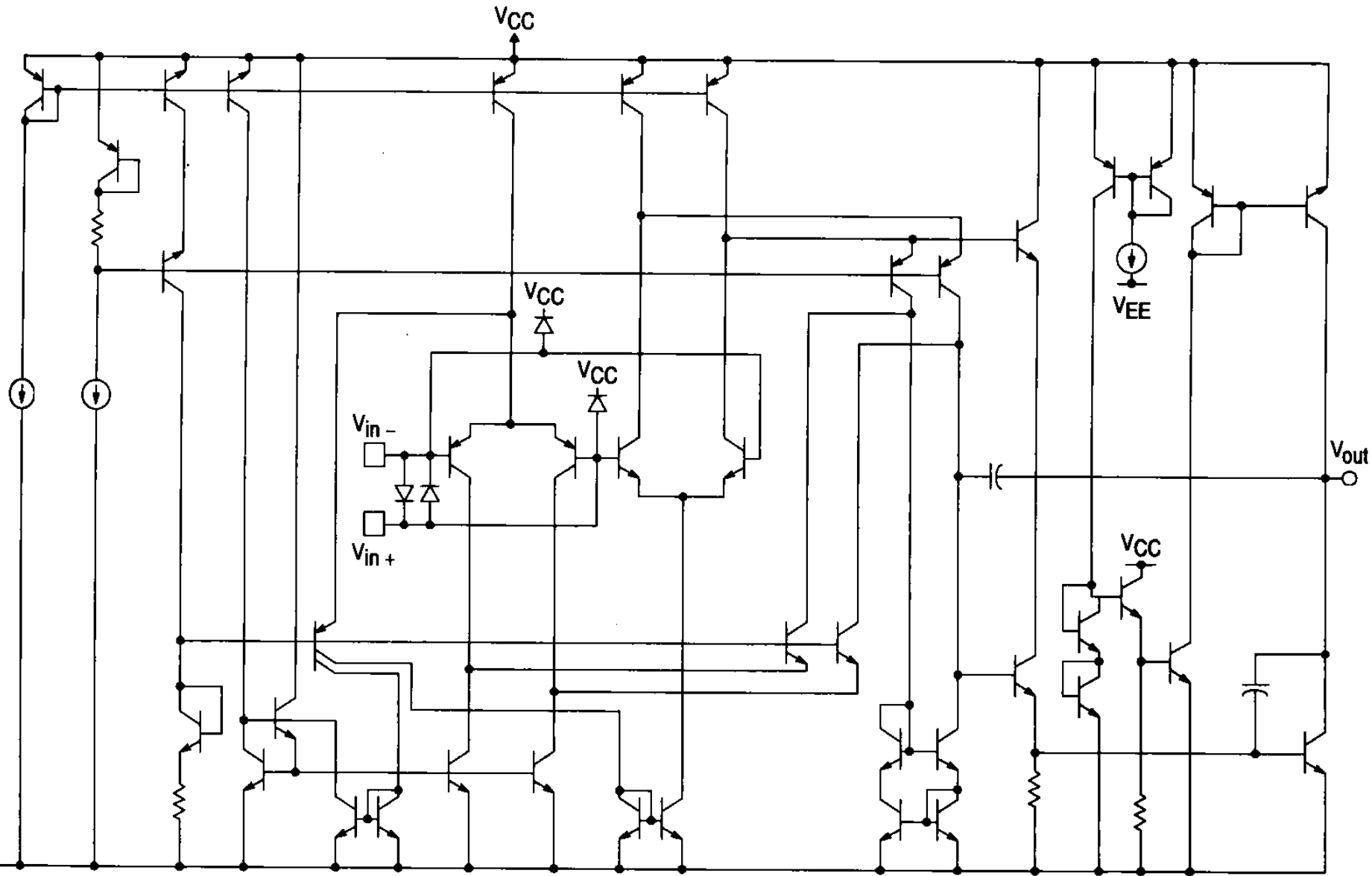

LM741- OP opste namjene

EQUIVALENT CIRCUIT SCHEMATIC

(1/4 of Circuit Shown)

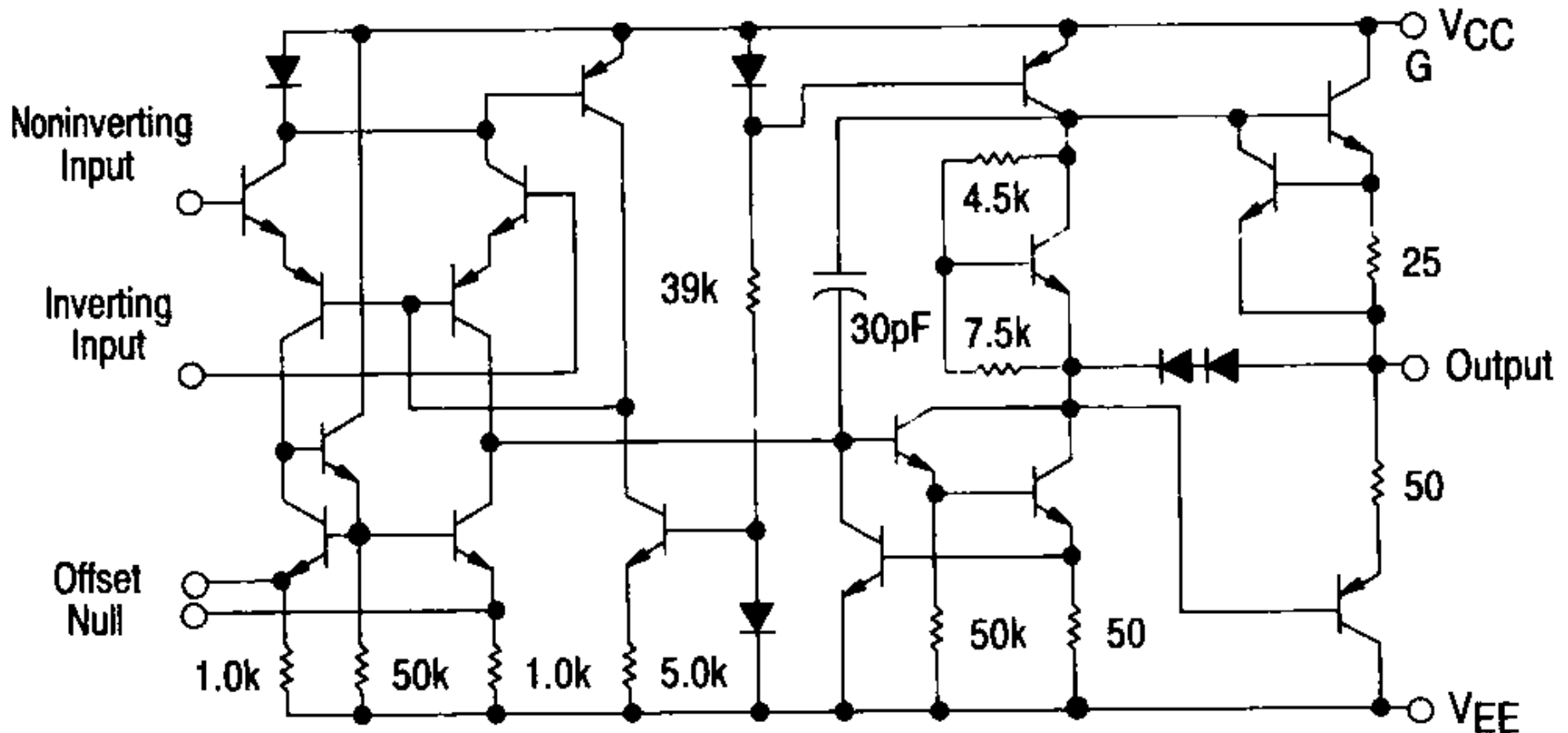

Kod prekoračenja max. zajednickog napona na ulazu OP dolazi do obrtanja faze (Phase reversal)

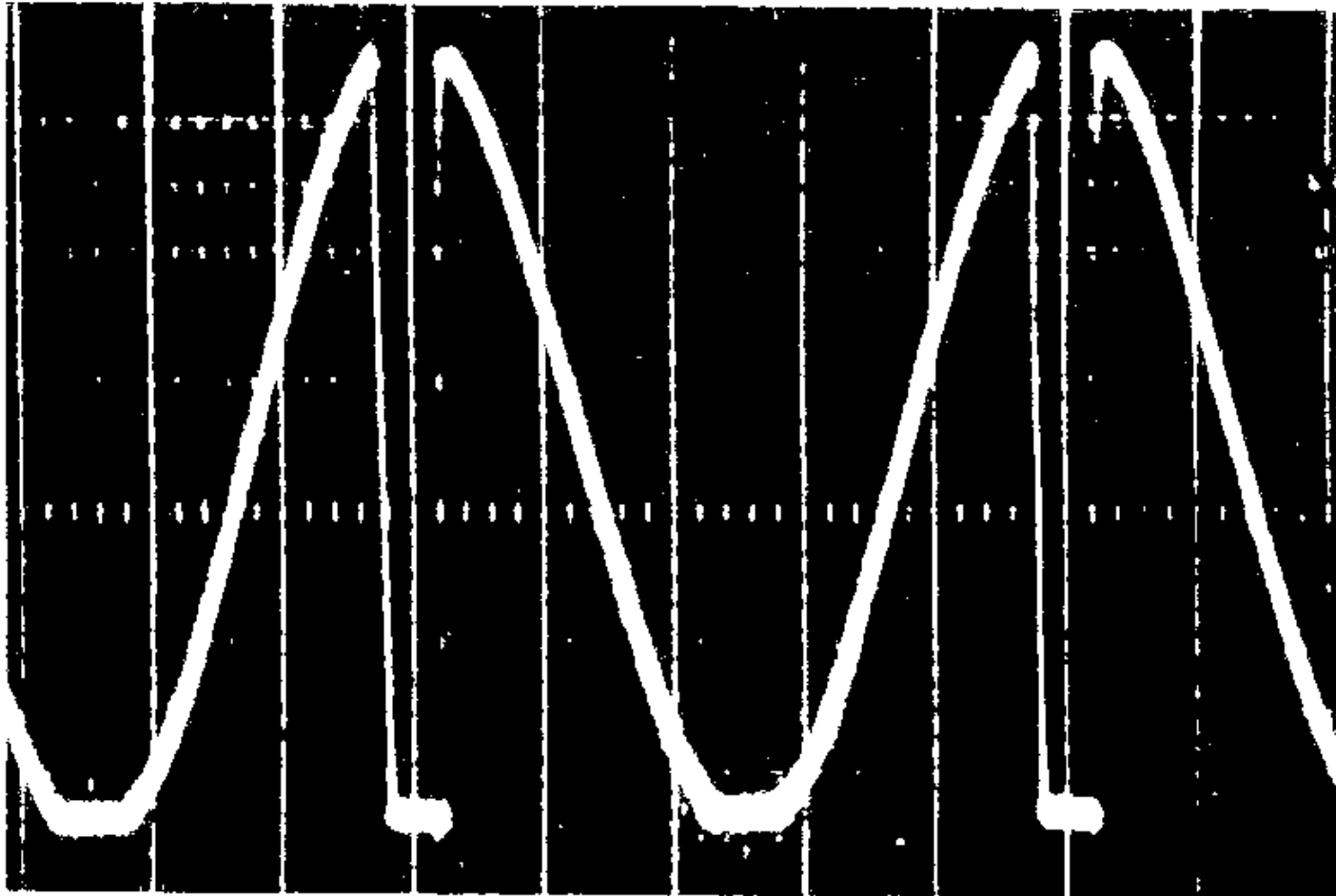

PHASE REVERSAL

The OP-467 is immune to phase reversal; its inputs can exceed the supply rails by a diode drop without any phase reversal.

*Teflon is a registered trademark of E.I. du Pont Co.

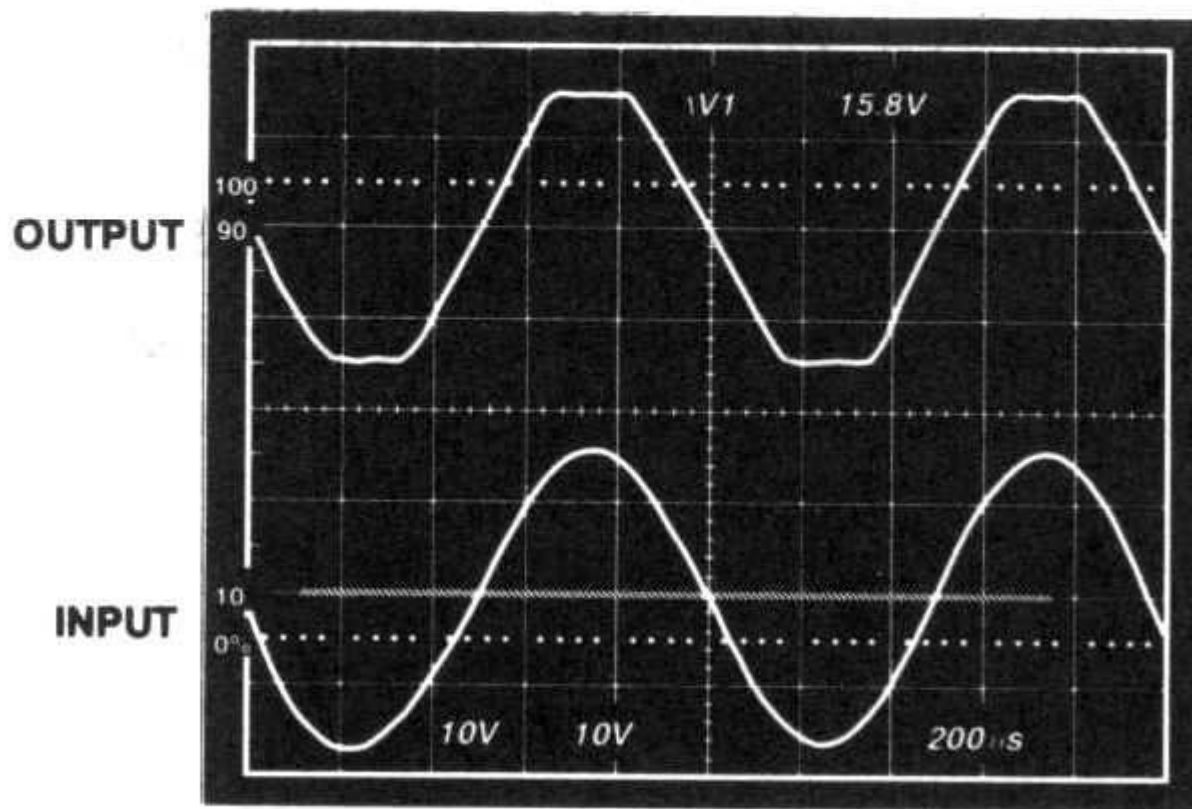

Figure 36. No Phase Reversal ($A_V = +1$)



BASIC LANGUAGE

Generator stepenica - diodna pumpa i integrator -

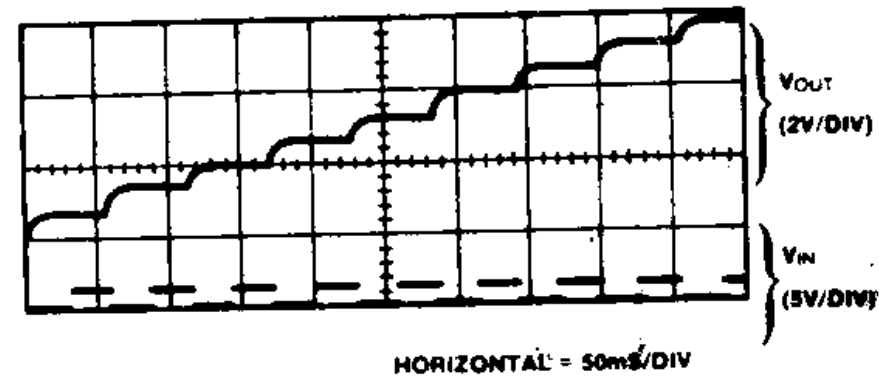
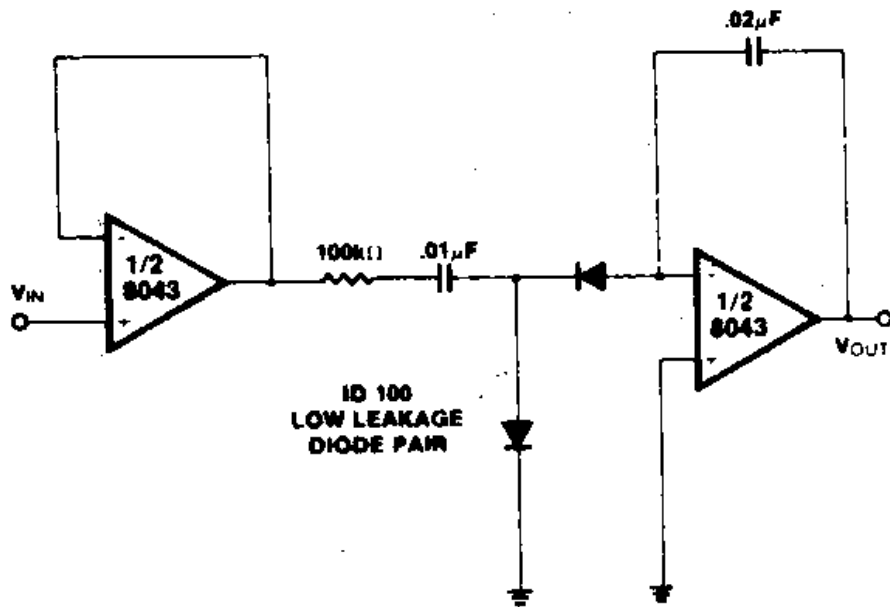

Figure 7: Staircase Generator Circuit

Analogni brojac (i generator spepenastih testera)

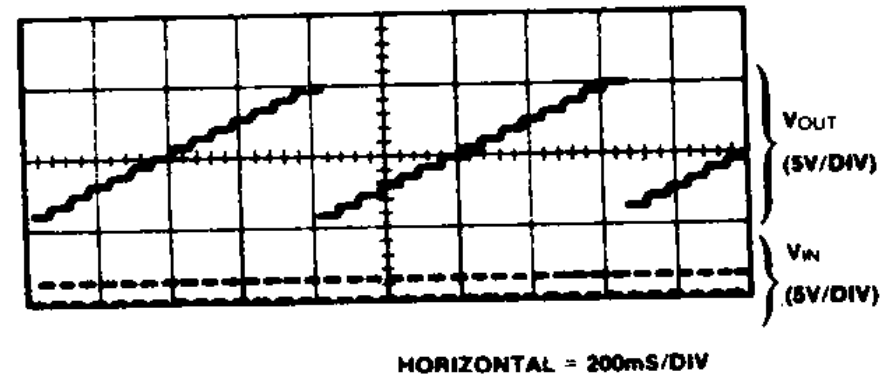
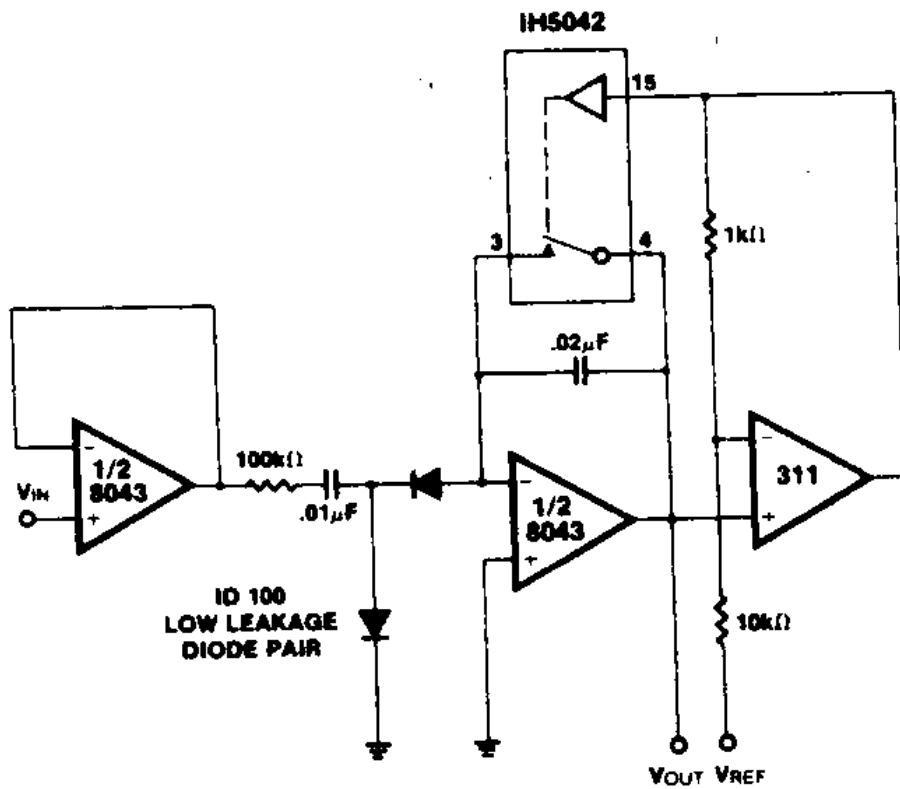

Figure 8: Analog Counter Circuit

Blokiranje napona napajanja

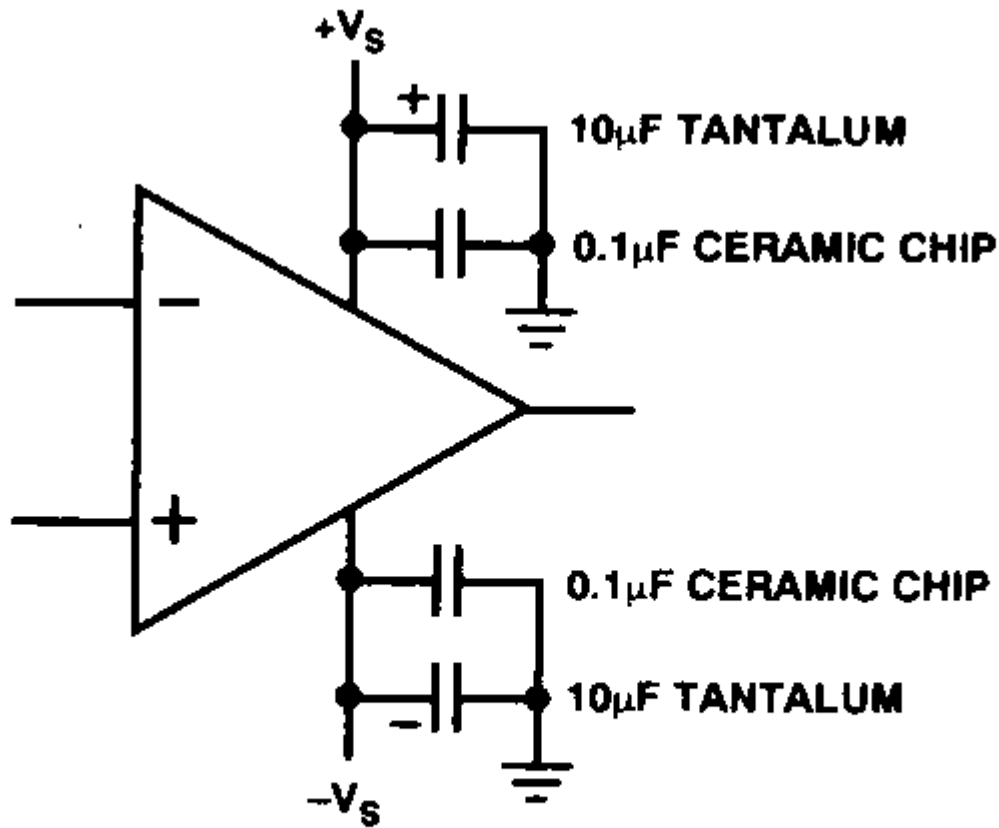
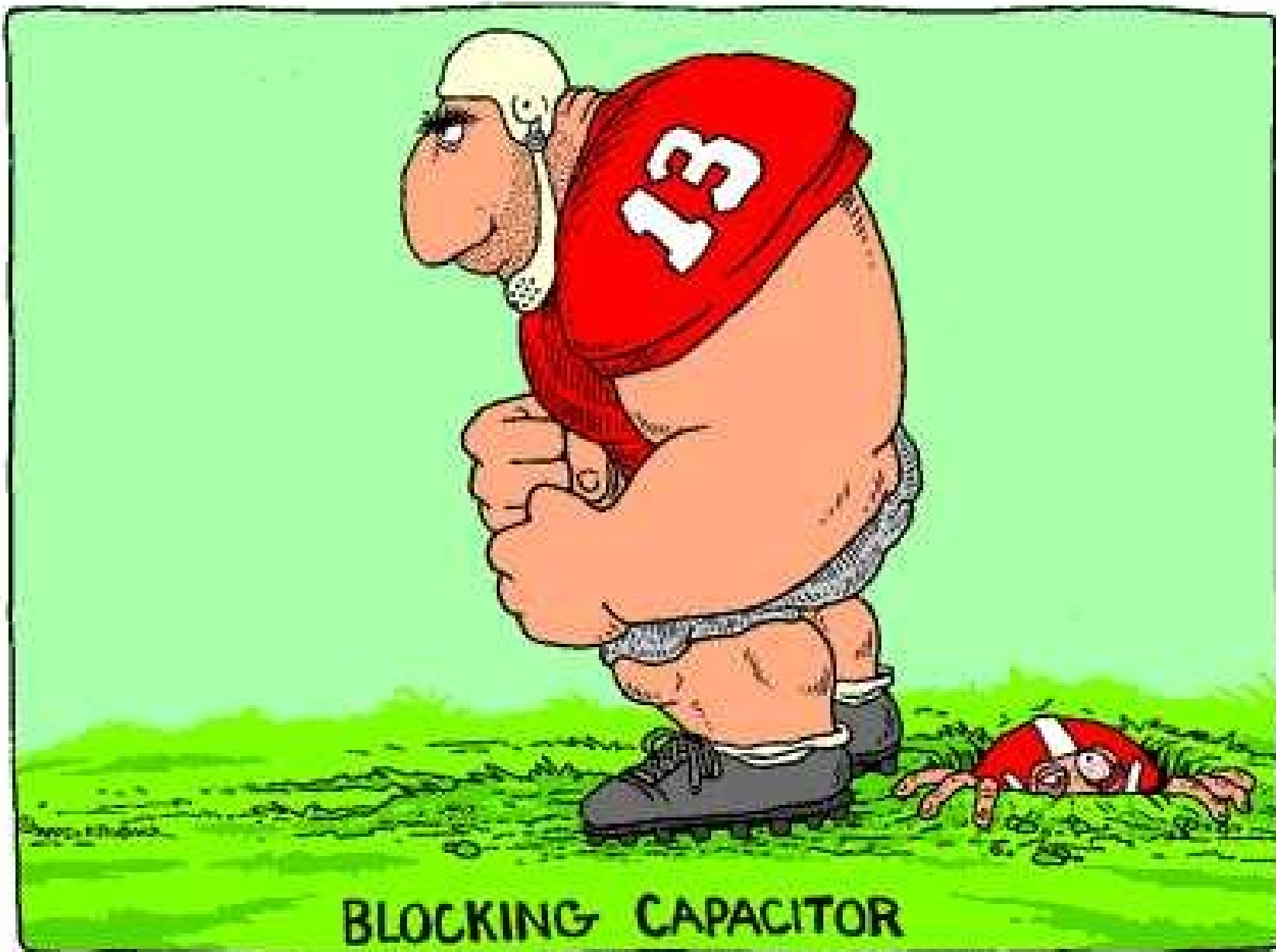

Figure 35. Recommended Power Supply Bypass



BLOCKING CAPACITOR

Figure 14. Audio Tone Control Amplifier

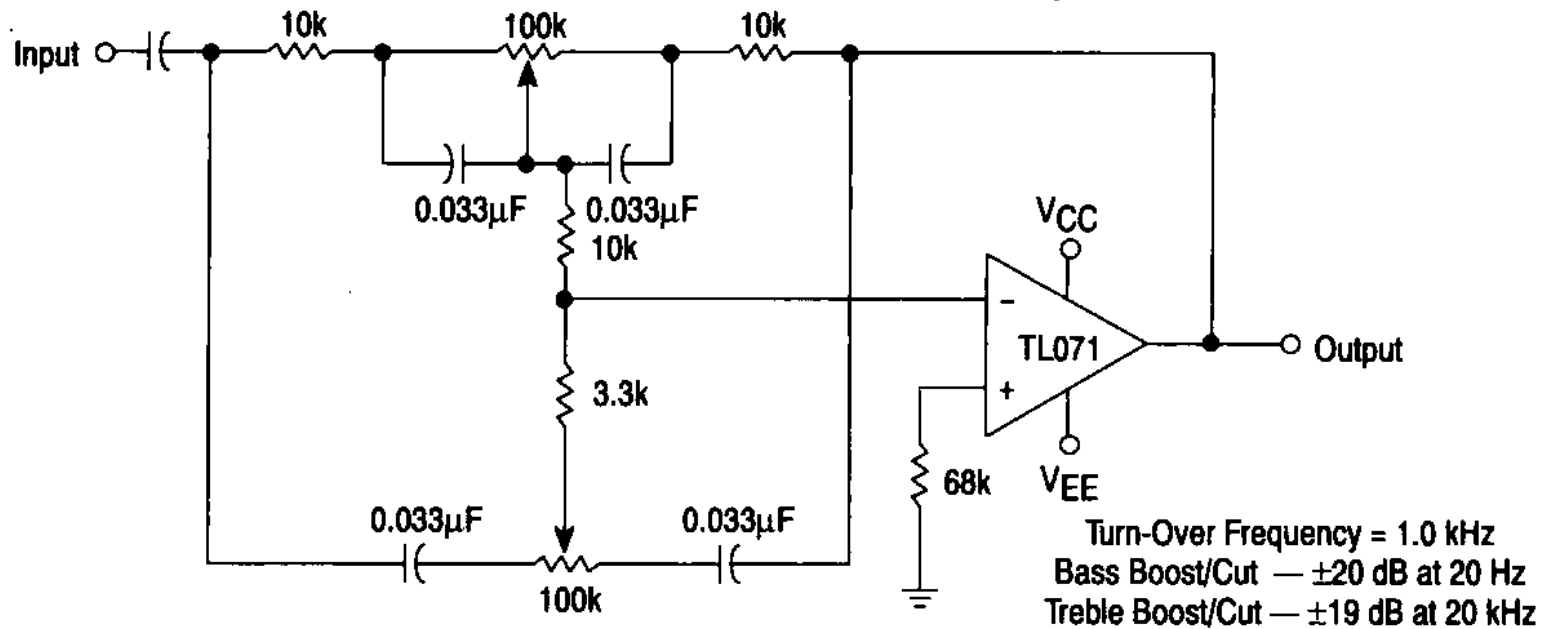
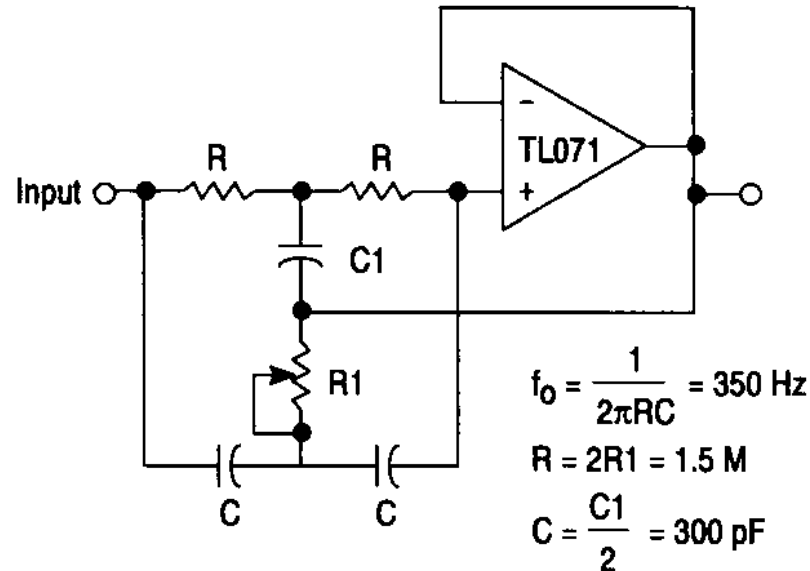

Figure 15. High Q Notch Filter



Obostrani pogon motora

Figure 9. Bidirectional Speed Control of DC Motors

For circuit stability, ensure that $R_x > \frac{2R_3 \cdot R_1}{R_M}$ where, R_M = internal resistance of motor.

The voltage available at the terminals of the motor is: $V_M = 2 \left(V_1 - \frac{V_S}{2} \right) + |R_O| \cdot I_M$

where, $|R_O| = \frac{2R_3 \cdot R_1}{R_x}$ and I_M is the motor current.

